

AUSTRALIA

Patents Act 1990

SPECIFICATION

FOR THE INVENTION ENTITLED:

Animal restraining device

Applicant:

Australian Wool Innovation Limited

The invention is described in the following statement:

Animal restraining device

Field of the invention

The present invention relates to device for restraining animal. In particular, the present invention relates to a device for restraining a sheep during shearing of the sheep.

5 Background of the invention

Shearing of sheep, in the most part, has traditionally been a labour intensive and arduous task, and requiring high levels of physical strength of shearers in order to capture, manipulate and hold a sheep whilst the sheep is being shorn.

10 Traditionally, shearers have held a sheep with one arm around the body of the sheep whilst bending over the animal and progressively removing the fleece with mechanically driven shearing devices or clippers. This task places large strains upon the lower back of a shearer and, in particular when an animal may unexpectedly move, turn or rotate its body, exposes a shearer to impact loads and damage of the lower spine. Such damage to the lumbar region not only results in pain to a shearer but also results in loss of
15 flexibility leading to a reduction in sheep shorn over time, and hence a reduction of income to the shearer. In many cases this injury results in a shearer having to exit the industry.

In developing a better shearing process and position, specialised braces and straps
20 have been used in an attempt to secure a sheep during a shearing process, however, such methods and/or apparatus are often cumbersome and difficult to use, resulting in excessive time in securing the animal and also resulting in agitation to the animal.

During shearing season, the time taken for a shearer to remove the fleece from a single animal effectively indicates the efficiency and profitability of the process. Furthermore, accuracy and quality of shearing further influences the profitability and efficiency of a
25 shearing station. Shearers who shear wool rapidly from the animal will typically often earn a higher income than those who are slower in removing the wool from the animal, assuming the quality of the shorn fleece is not compromised during shearing.

The present invention has sought to provide a device and system which overcome or partly ameliorate at least some of the disadvantages associated with animal restraining devices and methods as experienced by those of the prior art.

Summary of the invention

5 In broad concept the invention provides an animal restraint device comprising:

a generally elongate member one end of which is adapted to be mounted adjacent to a shearing station, the other end of which is free to move, the elongate member being comprised of a plurality of segments each of which is movable relative to the adjacent segments through an arc of movement;

10 locking means for locking the segments relative to each other to substantially prevent the segments moving relative to each other; and

release means which is actuable to allow the segments to move relative to each other;

the device thus being flexibly moveable when the release means is actuated to thereby be moveable into a select position of animal restraint, and being relatively rigid when the

15 release means is not actuated and the locking means locks the segments together.

More specifically, the present invention provides a device for restraining an animal, the device comprising:

an articulated arm member having a fixed proximal end, a free distal end and comprising a series of generally cylindrical segments each having a passage extending
20 there-through and being arranged such that a central channel is formed through said elongate arm member from the proximal end to the distal end, each cylindrical segment being moveable relative to an adjacent cylindrical segment to provide articulation of said arm member whilst maintaining continuity of the central channel;

a elongate flexible tensioning member having a first end and a second end, the first end
25 being engaged with the arm member at the distal end and extending through the central

channel of said arm member, said tensioning member being movable relative to the cylindrical segments; and

an actuation means located at the proximal end of said arm member, said actuation means being adapted to apply a tensile locking load to said tensioning member such
5 that the ends of the arm member are urged towards each other, thus urging each cylindrical segment towards an adjacent cylindrical segment and so as to fix each segment relative to an adjacent cylindrical segment so as to lock the arm member at a first selected articulation configuration;

a release means for at least partially releasing said locking load such that the cylindrical
10 segments are moveable relative to adjacent cylindrical segments so as to allow the arm member to articulated to a second selected articulation configuration.

In a preferred embodiment, each cylindrical segments bear directly upon an adjacent cylindrical segment. Preferably, the cylindrical segments have a convex curved first end and concave curved second end, wherein the ends of the cylindrical segments are
15 curved such that the first end of a cylindrical segment is at least partly housed within the second end of an adjacent cylindrical segment to provide rotational motion between adjacent cylindrical segments. The ends of the cylindrical segments are preferably adapted to limit the allowable movement between adjacent cylindrical segments to a predetermined maximum angular displacement.

20 The cylindrical segments are preferably cylindrical in cross-section and are preferably formed from a metal or metal alloy. Preferably, the first and second ends of the cylindrical segments have a hardness in the range of from 25 to 35 Rockwell C, more preferably about 30 Rockwell C.

25 Preferably, the cylindrical segments have greater diameter towards the fixed end of the arm member than that those towards the free end of the arm member. The passages of cylindrical segments preferably include a flared portion so as to reduce point loading of the tensioning member upon the cylindrical segments upon locking of the arm in an articulated arrangement.

The tensioning means is preferably in the form of a flexible cable and is engaged with the distal end of the arm member and is engaged with the actuation means at the proximal end of the arm member. The tensioning member preferably maintains the cylindrical segments of the arm in said series.

- 5 The device preferably includes a base portion at the proximal end of the arm for mounting the device to a work platform. The actuation means is preferably supported by the base portion and is adapted to urge the arm member towards the base portion upon activation. The actuation is preferably an air operated bellows device. Alternatively, the actuation means may be a hydraulic device, an electro-solenoid device or an electric-
10 actuator device. A lever mechanism may be provided to provide mechanical advantage to the actuator means when tensioning the tensioning means.

The device preferably includes a handle portion located at the distal end of the arm member for allowing the arm member to be moved to a predetermined articulation configuration. The release means is preferably provided as user-operable switch on the
15 handle to allow for activation and deactivation of the actuation means at the distal end of the arm member. The switch is preferably adapted to maintain the actuator means in an activated state such that the arm member is in a locked configuration. Preferably, the switch is adapted to deactivate the actuator means upon gripping of the handle portion such that a user may unlock the arm member and move the arm member to a
20 predetermined articulation configuration with the use of one hand. The switch preferably comprises two separate switch members which are located apart from each other and configured such that deactivation of the actuation means is effected only upon depression of both switch members. The switch members are preferably located apart from each other in a manner so as to reduce the likelihood of accidental depression by
25 either a user or by movement of an animal.

The base portion of the device is adapted to be mounted to a shearing platform for the shearing of sheep, and the arm is configured to restrain a sheep to the shearing platform. An end effector may be provided at the distal end of the arm to secure the sheep by applying pressure in the stifle joint or other body area of the sheep.

Brief description of the drawings

A preferred embodiment of the device of present invention will now be described by way of non-limiting example only with reference to the accompanying drawings in which:

Figure 1 shows a photographic representation of a preferred embodiment of a device
5 according to the present invention in a first articulation configuration;

Figure 2 shows a photographic representation of the device of Figure 1 in a second articulation configuration restraining a sheep by the sheep's hind limbs;

Figure 3 shows a pictorial representation of the device as depicted in Figures 1 and 2;

Figure 4 shows perspective view of components of the device as depicted in Figure 3 in
10 an exploded arrangement;

Figure 5 shows a sectional view of the components as depicted in Figure 4;

Figure 6 shows a sectional view of a portion of the device as depicted in Figure 3 in an articulated arrangement;

Figure 7 shows a perspective pictorial representation of the base portion of the device
15 as depicted in Figure 3;

Figure 8 shows a perspective pictorial representation of the handle portion of the device as depicted in Figure 3; and

Figure 9 shows an enlarged photographic representation of a handle portion of the device of Figures 1 and 2.

20 Detailed description of drawings

The following description refers to preferred embodiments of a device according to the present invention. To facilitate an understanding of the invention, reference is made in the description to the accompanying drawings whereby the device is illustrated in a

preferred embodiment. Similar components between the embodiments are identified by the same reference numerals.

Referring to Figures 1 and 2, there is shown an embodiment of a device 10 for restraining an animal, in this case a sheep 70, to a shearing platform 60 in accordance with the present invention. The device 10 comprises an articulated arm member 30 which is mounted to a shearing table 60 via the base portion 20. The articulated arm 30 is adapted to be moved by a user to various configurations so as to constrain the sheep 70 in a required position during a shearing process. The device 10 includes a distal portion 40 having a handle 44 by which a user may manipulate the device to various configurations of articulation upon depression of release switches 42a and 42b. As shown in Figure 2, a sheep 70 is restrained by applying a force to the hind legs of the sheep 70 by the arm member 30 of the device 10 with the sheep 70 lying upon its back. The arm member 30 of the device 10 is locked in the required articulation configuration such that the sheep is restrained and cannot move during the shearing process.

Various configurations of articulation of the arm member 30 may be used depending upon the particular portion of the sheep which is to be shorn. Alternatively, in another configuration, an end effector 46 may be provided at the distal end portion 40 to secure the sheep 70 by applying a flank restraint technique by applying pressure in the stifle joint area of a sheep. More than one device 10 may be provided for securing a sheep 70 if required. As will be appreciated by those skilled in the art, the arm member 30 of the device 10 may be moved to various alternate configurations of articulation alternate to those not depicted within Figure 2 when securing or restraining a sheep during shearing.

Referring to Figures 3, 4, 5 and 6, the arm member 30 of the device 10 comprises a series of generally cylindrical segments 32a, 32b, 32c each having a passage 34a, 34b and 34c extending there-through which provide a channel through the arm member 30 when the cylindrical segments 32a, 32b and 32c are arranged coaxially. The cylindrical segments 32a, 32b, 32c include a concave curved portion 36a, 36b, 36c at a first end, and a convex curved portion 38a, 38b, 38c at a second end respectively which allows adjacent cylindrical segments to be partly housed within each other and allow the

access of each cylindrical segment to be varied with respect to an adjacent cylindrical segment, thus allowing articulation of the arm as shown in Figure 6.

A tensioning member in the form of a tensioning cable 50 is provided which is engaged at the distal end portion of the device 10 and extends freely through a channel formed by the passages 34a, 34b, 34c of the cylindrical segments 32a, 32b, 32c respectively.

In the present embodiment, the cylindrical segments are adapted to restrict the amount of angular variations between adjacent cylindrical segments such that a gradual articulation is formed along the length of the arm member 30 during articulation of the arm member 30. In the present embodiment, the cylindrical segments are circular in cross-section and are formed from a metal or a metal alloy. The convex surfaces 36a, 36b, 36c and the concave surfaces 38a, 38b, 38c are hardened so as to have a hardness preferably of about 30 Rockwell C. In the present embodiment, cylindrical segments 32a which are towards the proximal end of the arm member 30 have a greater outer diameter than the cylindrical segments 32b towards the mid portion of the arm member 30, which in turn have a greater diameter than cylindrical segments 32c towards the distal end of the arm member 10. The cylindrical segments 32a, 32b, 32c include a flared portion 31 within the passages 34a, 34b, 34c respectively so as to reduce point loading of the tensioning cable 50 against the cylindrical segments. This provides a more uniform loading to the cylindrical segments and reduces wear to both the cylindrical segments and the cable member 50.

Referring to Figure 7, the base portion 20 of the device 10 comprises a mounting portion 22 and extension arms 26 to which the actuation means 24 is mounted. In the present embodiment, the cable member 50 is connected to the actuation means 24 via lever arm 28 which is pivotally connected to the extension arms 26 via pivot member 21 and which is connected to the actuator via pivot member 23. The tensioning cable 50 is engaged with an activation means 24 such that upon activation of the activation means 24, the tensioning cable 50 is drawn towards the proximal end of the device 10, thus urging the ends of the arm member 30 towards each other which in turn urge each cylindrical segment against an adjacent cylindrical segment and towards the proximal

end so that the arm member 30 is fixed in a predetermined or required configuration of articulation.

The distance between pivot member 21 and pivot member 23 provides a mechanical advantage to the cable member 50 via the actuation means 24. In the present embodiment, the actuation means 24 is an air operated bellows-type device. Alternatively, other actual actuation means may be utilised, for example, a hydraulic device, an electro-solenoid device or an electric-actuator device, without departing from the scope of the invention. It will be appreciated by those skilled in the art that the length of the lever arm 28 is determined by the force which the actuation means 24 is capable of applying and the required tension within the cable member 50 such that the arm member 30 is secured firmly by the cylindrical segments being urged against adjacent cylindrical segments.

Referring to Figures 8 and 9, at the distal end 40 of the device 10 a handle portion 44 is provided on which deactivation switches 42a and 42b are provided. The deactivation switches 42a and 42b are configured so as to be in a normally closed circuit configuration such that when not depressed by a user, power is provided to the actuator means 24 so as to maintain the cable member 50 in a tension state, thus maintaining the arm member in a locked configuration. Furthermore, the switch members 42a and 42b are wired in a series configuration such that only when both switches 42a and 42b are depressed by a user the actuator means is deactivated so that the arm member 30 may be manipulated by the user to a required configuration of articulation. By providing two switches as in the present embodiment, the likelihood of switch being accidentally depressed either by an operator or a sheep is significantly reduced as both switches 42a and 42b must be simultaneously depressed to deactivate the activation means 24.

By providing the switches 42a and 42b integrally with the handle portion 44 at the distal end 40 of the device 10, a user may deactivate the actuation means 24 and manipulate the arm member 30 to a required position so as to appropriately restrain an animal by use of a single hand. Thus, the user may manipulate an animal into an appropriate position with one hand whilst manipulating the arm 30 of the device 10 with the other, so as to restrain the animal without assistance from another person. It will be appreciated

by those skilled in the art that single-handed operation of the device 10 provides significant advantages and benefits.

The present invention allows a person to single-handedly manipulate and restrain a sheep to a shearing platform during shearing of the sheep. The present invention
5 provides a universal device 10 for restraining an animal in various positions when shearing various parts of the animal's body rapidly and humanely in various configurations and positions as required. Thus, the need for a shearer to restrain a sheep with one arm whilst shearing is removed, which reduces the likelihood of injury to the shearer due to sudden movements or jerking of the sheep during the shearing
10 process, and also reduces the likelihood of the sheep being injured or cut from such sudden movements.

The present invention, by providing a device which allows a shearer to manipulate and securely restrain a sheep for shearing, provides for significant cost saving, safety to both animal and shearer, advantages which will be appreciated by those skilled in the
15 art to be of significant advantage.

It will be understood that the invention disclosed and defined in this specification extends to all alternative combinations of two or more of the individual features mentioned or evident from the text or drawings. All of these different combinations constitute various alternative aspects of the invention.

20

It will also be understood that the term "comprises" (or its grammatical variants) as used in this specification is equivalent to the term "includes" and should not be taken as excluding the presence of other elements or features.

Dated : 2 November 2005

Australian Wool Innovation Limited

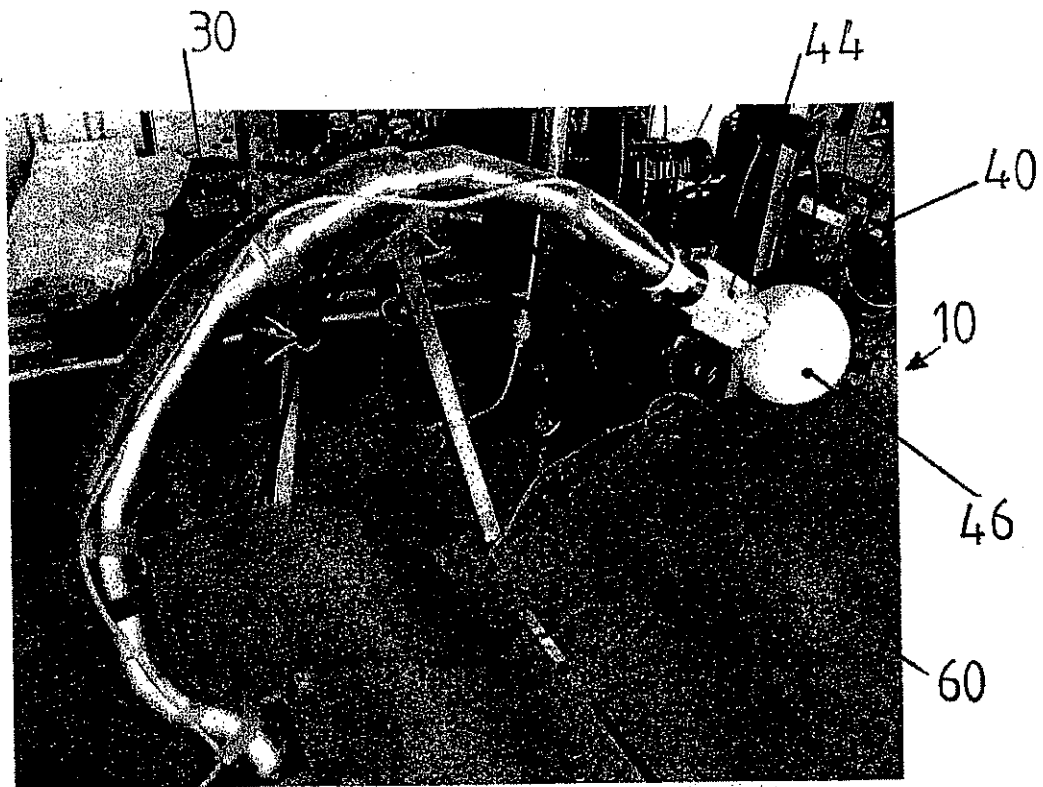

FIG 1.

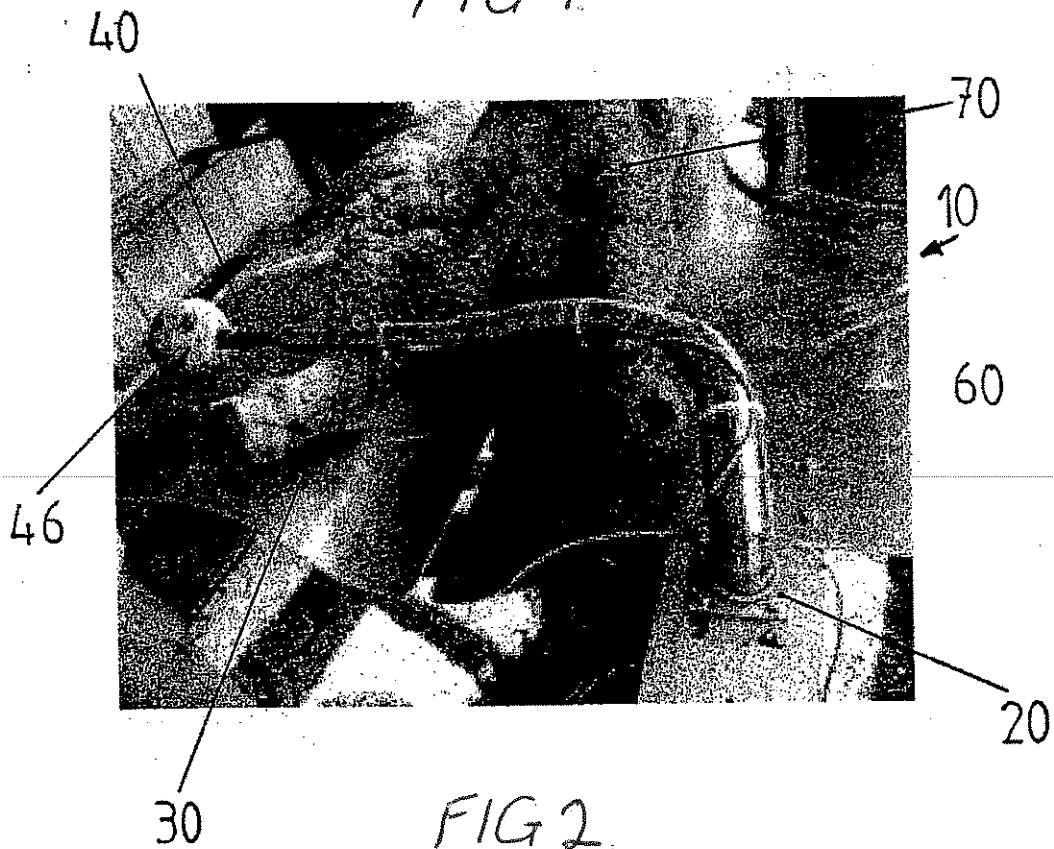

FIG 2.

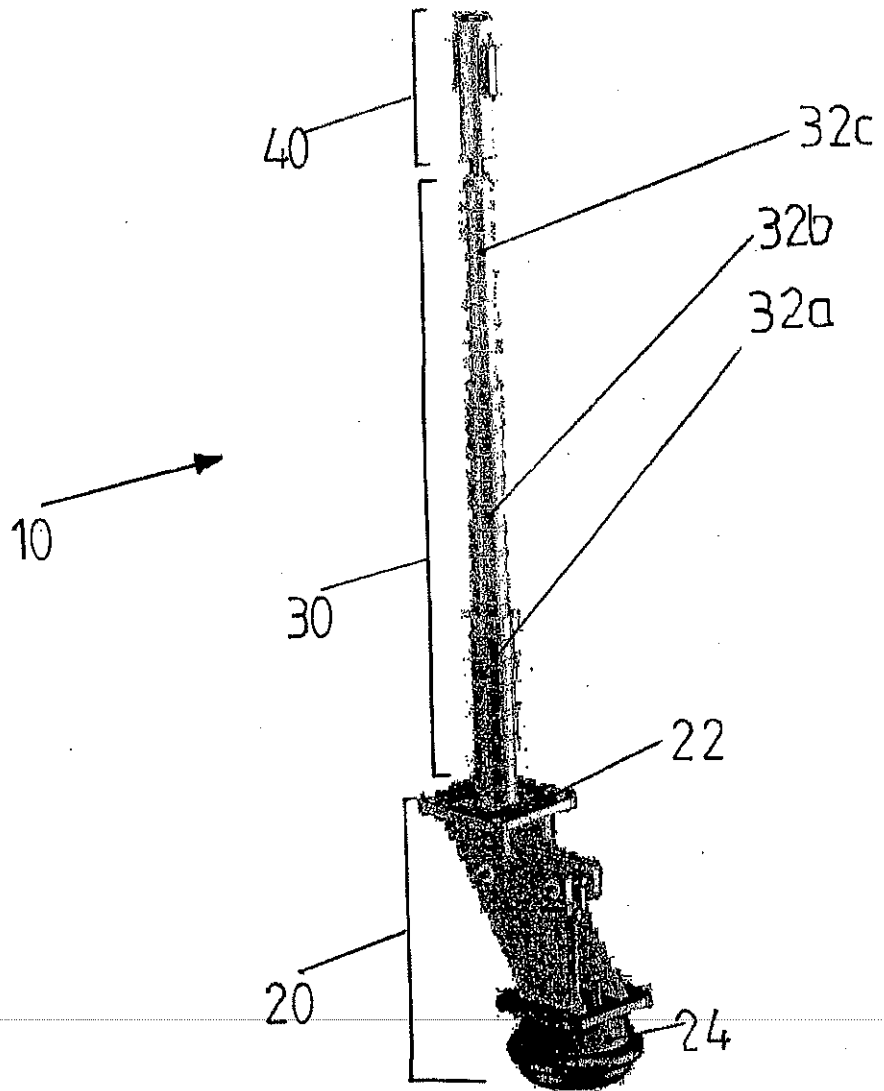

FIG. 3

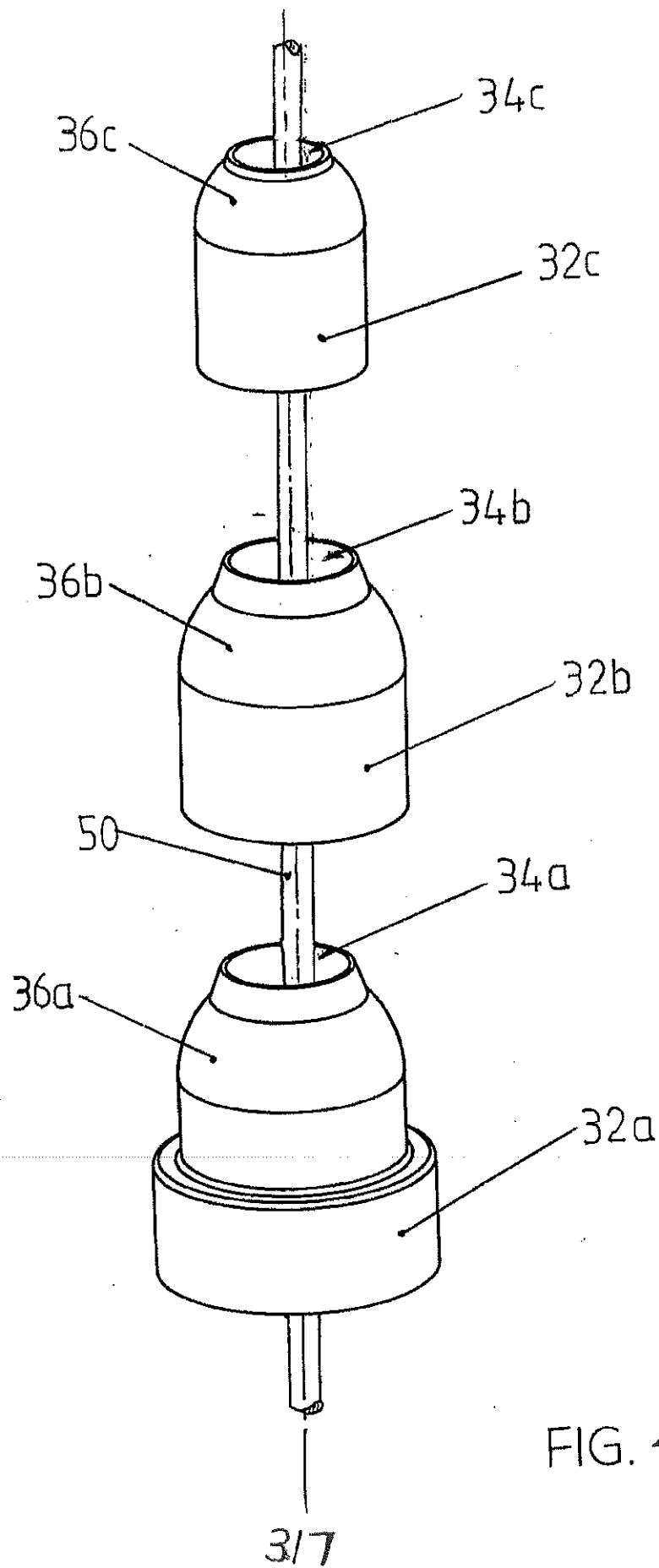

FIG. 4

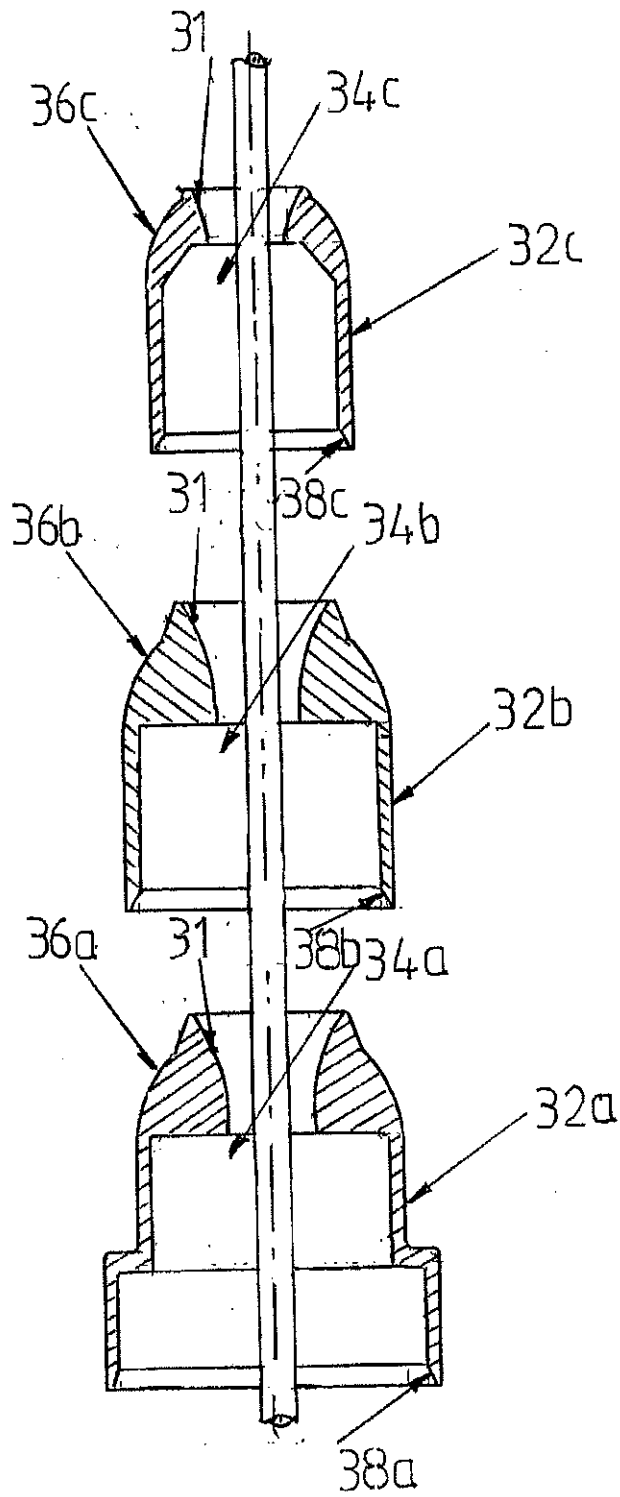

FIG. 5

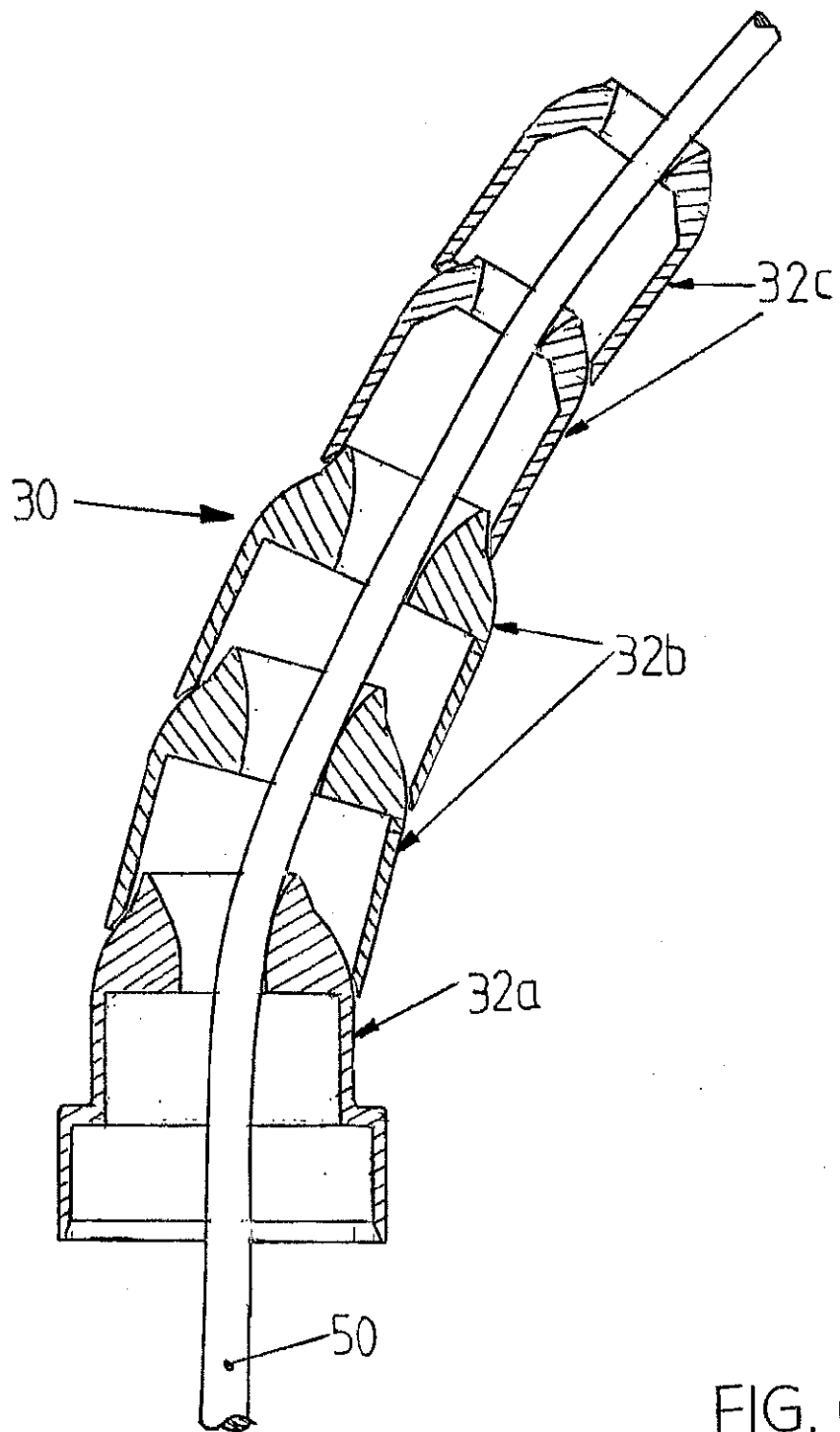

FIG. 6

517

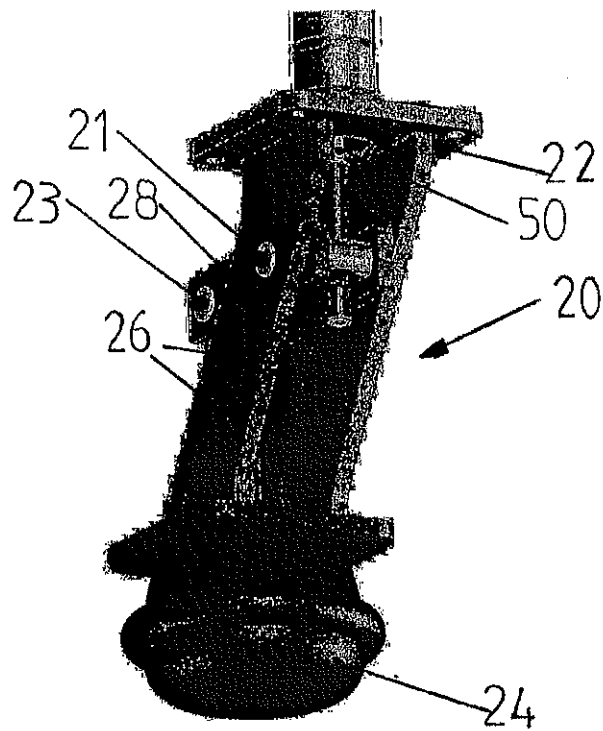

FIG. 7

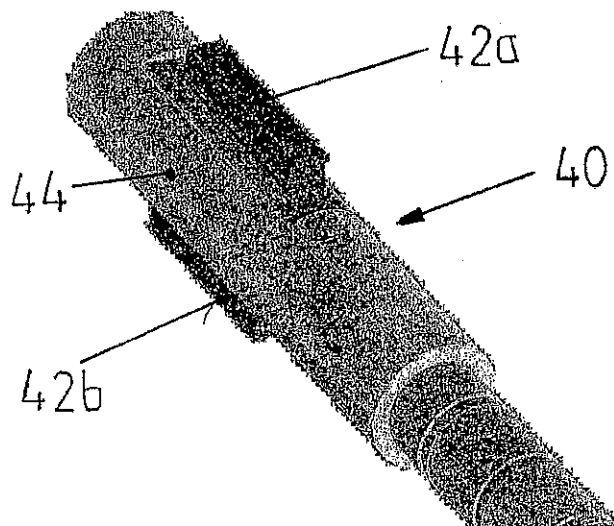

FIG. 8

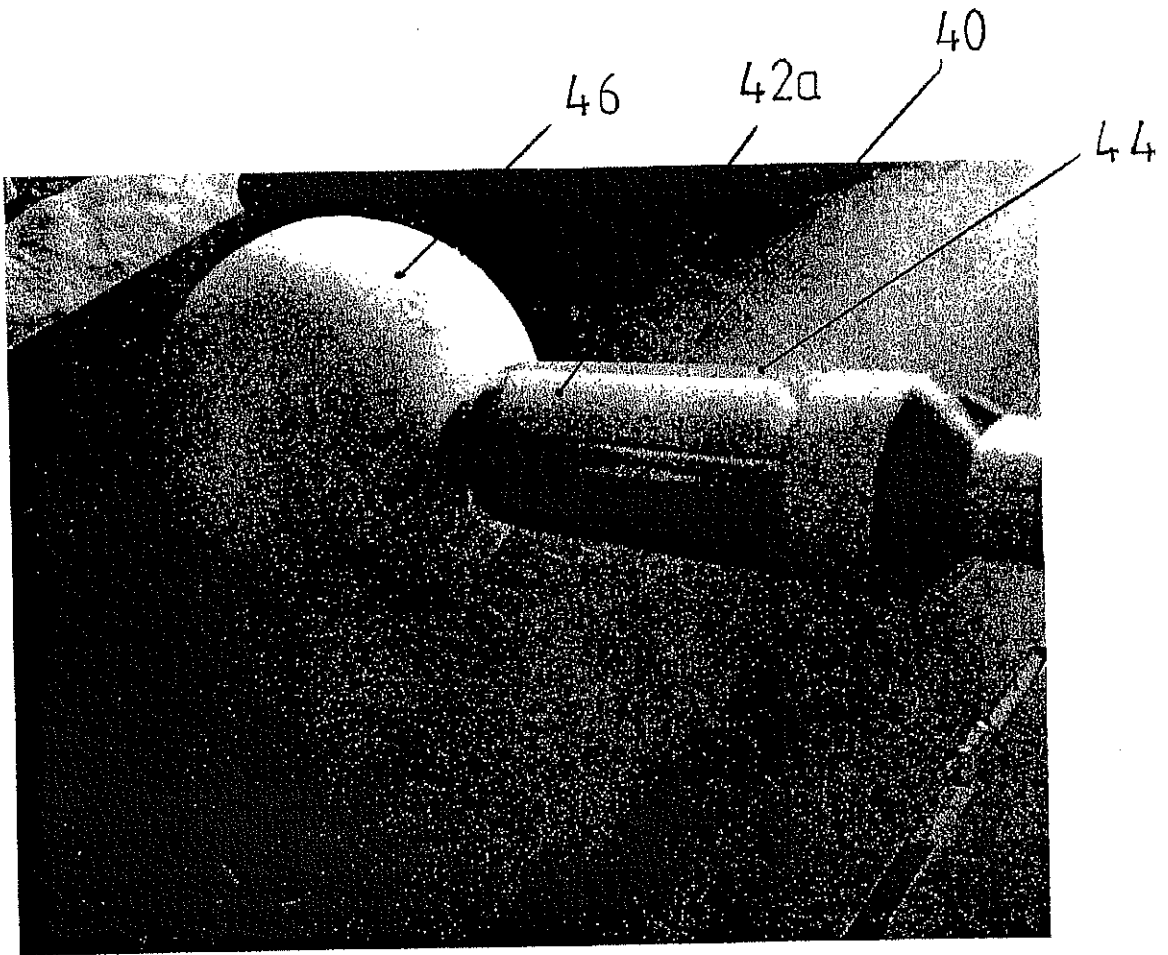

FIG. 9