

**(12) PATENT APPLICATION**  
**(19) AUSTRALIAN PATENT OFFICE**

(11) Application No. **AU 199723597 A1**  
(10) Patent No. **712395**

(54) Title  
**A restraint**

(51) International Patent Classification(s)  
**A01K 015/04                      B25B 011/00**  
**A01K 015/00                      F16B 002/10**  
**A61D 003/00                      F16B 007/14**  
**B25B 005/06**

(21) Application No: **199723597**                      (22) Date of Filing: **1997.05.23**

(30) Priority Data

(31) Number                      (32) Date                      (33) Country  
**PO0291                                      1996.06.05                                      AU**

(43) Publication Journal Date: **1997.12.11**

(44) Accepted Journal Date: **1999.11.04**

(71) Applicant(s)  
**Chain Shearing Ltd**

(54) Inventor(s)  
**Fred Wybrow; Walter Homann**

AUSTRALIA  
Patents Act 1990

**PATENT REQUEST: STANDARD PATENT  
and  
NOTICE OF ENTITLEMENT**

We, CHAIN SHEARING LTD, being the person(s) identified below as the Applicant, request the grant of a patent to the person identified below as the Nominated Person, for an invention described in the accompanying standard complete specification. Full application details follow.

[71] Applicant: Chain Shearing Ltd

Address: 1/277 Great Eastern Highway  
Belmont, Western Australia  
Australia 6104

[70] Nominated Person: Applicant

[54] Invention Title: A RESTRAINT

[72] Name(s) of actual inventor(s): Fred WYBROW  
Walter HOMANN

[74] Address for service in Australia:

GRIFFITH HACK, Patent and Trade Mark Attorneys, 256 Adelaide Tce,  
Perth 6000, Western Australia, AUSTRALIA. Attorney Code: HP

**ASSOCIATED PROVISIONAL APPLICATION(S) DETAILS**

[60] Application Number(s) and Date(s)

PO 0291 filed 5 June 1996

We, CHAIN SHEARING LTD

of 1/277 Great Eastern Highway  
Belmont, Western Australia  
Australia 6104

being the applicant in respect of this Application state the following:-

The person nominated for the grant of the patent:

would be entitled to have assigned to it a patent granted to any of the actual inventors in respect of the said invention

The person(s) nominated for the grant of the patent:

is the applicant of the provisional application listed on the patent request form.

Drawing number recommended to accompany the abstract Figure 1

Dated this 23rd day of May 1997.

CHAIN SHEARING LTD

GRIFFITH HACK



Patent Attorneys for and  
on behalf of the Applicant



AU9723597

**(12) PATENT ABSTRACT**      **(11) Document No. AU-A-23597/97**  
**(19) AUSTRALIAN PATENT OFFICE**

- (54) Title  
A RESTRAINT
- (51)<sup>6</sup> International Patent Classification(s)  
A01K 015/04      A01K 015/00      A61D 003/00      B25B 005/06  
B25B 011/00      F16B 002/10      F16B 007/14
- (21) Application No. : 23597/97      (22) Application Date : 23/05/97
- (30) Priority Data
- (31) Number      (32) Date      (33) Country  
PO0291      05/06/96      AU AUSTRALIA
- (43) Publication Date : 11/12/97
- (71) Applicant(s)  
CHAIN SHEARING LTD
- (72) Inventor(s)  
FRED WYBROW; WALTER HOMANN
- (74) Attorney or Agent  
GRIFFITH HACK , 256 Adelaide Terrace, PERTH WA 6000
- (57)

A restraint 10 comprises first and second parts 12 and 14 which are pivotally coupled together about pin 16. The restraint 10 has a closed state in which the first and second parts 12 and 14 are releasably locked in mutually facing relationship, and an opened state in which the first and second parts, 12 and 14, can be pivoted relative to each other. An elastic band 18 is connected between the first and second parts 12, 14 and has a portion 20 which extends across an opening 22 formed between the first and second parts 12, 14 when the restraint 10 is in the opened state. In use, when the restraint is in the opened state, a member such as the hind leg of a sheep, can be pushed against the portion 20 of the elastic band 18 causing the parts 12 and 14 to pivot toward each other until the restraint 10 enters the closed state thereby restraining the legs of the sheep between the portion 20 and the first and second parts 12 and 14.

**AUSTRALIA**

**PATENTS ACT 1990**

**COMPLETE SPECIFICATION FOR A  
STANDARD PATENT**

Name of Applicant: CHAIN SHEARING LTD

Address of Applicant: 1/277 Great Eastern Highway  
Belmont, Western Australia  
Australia 6104

Actual Inventor: Fred WYBROW and Walter HOMANN

Address for Service: Griffith Hack, Patent & Trade Mark  
Attorneys of 256 Adelaide Terrace (6th  
Floor), Perth, Western Australia,  
Australia 6000

Standard Complete Specification for the invention entitled:

**A RESTRAINT**

Details of Associated Provisional Applications:

PO 0291 filed 5 June 1996

The following is a full description of this invention, including the best method of performing it known to me:-

A RESTRAINT

The present invention relates to a restraint, and in particular, but not exclusively, to an arm or leg restraint for an animal.

5 When handling farm animals such as sheep, it is necessary from time to time to restrain one or more of their limbs in order to carry out various husbandry or other procedures. Various types of limb restraints have been known and used for such purposes. In the simplest form, a restraint may  
10 be in the form of a length of rope or cord which can bind a limb to a fixed member such as a post or be wound around two or more limbs. While this type of restraint requires essentially no manufacture and is simple to use in that it only requires a person to wind the rope and tie a knot, it  
15 is time consuming to use and not well suited to automated animal handling equipment.

Another type of restraint commonly used is in the form of a metallic shackle or cuff generally in the shape of a "C" with a gate pivotally connected at one end of the C and  
20 releasably lockable to the other end of the C. This type of restraint is easier to use than the ropes or cords described above but is limited in use to animals and more particularly, limbs of a particular size.

The present invention was developed with a view to  
25 providing a restraint for the limbs of sheep which is easy to use and can accommodate more than one limb or limbs of different sizes. Nevertheless, the invention in its broadest form can be used to restrain the limbs of other types of animals as well as for holding or restraining  
30 things and articles as diverse as carcasses in abattoirs; hand tools and equipment such as maybe used by plumbers or in engineering workshops; and, brooms and vacuum cleaner hoses in the home.

According to the present invention there is provided a restraint comprising:

5 first and second parts pivotally coupled together, said restraint having a closed state in which said first and second parts are releasably locked in a mutually facing relationship and, an opened state in which said first and second parts can be pivoted relative to each other; and,

10 an elastic band connected between said parts and having a portion which extends across an opening in said restraint that can be formed between said parts when said restraint is in said opened state;

15 whereby, in use, when said restraint is in said opened state a member can be pushed against said portion causing said parts to pivot toward each other until said restraint is in said closed state thereby restraining said member between said elastic band and said first and second parts.

20 Preferably said elastic band is provided with a surface having a relatively high friction coefficient to resist withdrawal of said member in a direction perpendicular to the length of said portion.

25 Preferably said portion is of a length so as to be relaxed when said restraint is in said closed state with no member restrained therein and to be under progressively increasing tension as said first and second parts pivot away from each other beyond a predetermined angular displacement.

30 Preferably said portion is further dimensioned so as to be in tension when said restraint is in said closed state and a member is restrained between said elastic band and said first and second parts.

Preferably said restraint further comprises releasable locking means for releasably locking said restraint in said closed state.

5 Preferably said releasable locking means comprises a first face on said first part and a second face on said second part of a configuration complementary to said first face, wherein when said restraint is in said closed state, said first and second faces engage each other to prevent relative pivotal movement of said first and second parts  
10 thereby locking said restraint in said closed state.

Preferably said releasable locking means further comprises first bias means for biasing said faces together and holding said faces in engagement when said restraint is in said closed state.

15 Preferably said releasable locking means further comprises manually operable means for separating said faces against said bias means to allow said first and second parts to pivot relative to each other thereby placing said restraint in said opened state.

20 Preferably said restraint further comprises second bias means for biasing said parts to pivot away from each other whereby, in use, when the state of said restraint is switched from said closed state to said opened state, said second bias means causes said first and second parts to  
25 pivot away from each other.

Preferably said second bias means comprises an elastic band or strap connected at opposite ends to respective ones of said first and second parts and extending across an axis about which said parts pivot.

30 Preferably said manually operable means comprises a pin

5 which extends collinearly with said axis, said pin being fixed to one of said parts with the other part movable about and along said pin. Preferably said first bias means acts between an end of said pin and the other of said parts.

Preferably each of said parts is arcuate in shape.

Embodiments of the present invention will now be described by way of example only with reference to the accompanying drawings in which:

10 Figure 1 is a side view of a first embodiment of the restraint when in an open state;

Figure 2 is a front view of the restraint when in an open state;

15 Figure 3 is a side view of a portion of the restraint when in a closed state;

Figure 4 is an exploded view from the side of a portion of the restraint;

20 Figure 5 is an end view of a leg holder assembly incorporating a second embodiment of the restraint shown in Figures 1-4; and,

Figure 6 is a side view of the leg holder assembly shown in Figure 5.

25 In the following description like numbers are used to represent corresponding features in the embodiments shown in Figures 1 to 4; and, Figures 5 and 6.

As shown in the accompanying drawings a restraint 10 comprises first and second parts 12 and 14 which are

pivotally coupled together about pin 16. The restraint 10 has a closed state (shown on the left hand side of Figure 5) in which the first and second parts 12 and 14 are releasably locked in a mutual facing relationship and an opened state (shown in Figures 1, 2 and on the right hand side of Figure 5) in which the first and second parts can be pivoted relative to each other. An elastic band 18 is connected between the first and second parts 12, 14 and has a portion 20 which extends across an opening 22 formed between the first and second parts when the restraint 10 is in the opened state. In use, when the restraint is in the opened state, a member such as the hind leg of a sheep can be pushed against the portion 20 of the elastic band 18 causing the parts 12 and 14 to pivot toward each other until the restraint 10 is in the closed state thereby restraining the sheep's leg between the portion 20 and the first and second parts 12 and 14.

In order to minimise the likelihood of the member or leg being withdrawn from the restraint 10 in a direction perpendicular to the portion 20, the band 18 is provided with a surface having a relatively high coefficient of friction. This may be achieved by making the band 18 from a strip of rubber.

The portion 20 is of a length so as to be relaxed when the restraint 10 is in the closed state as shown in Figure 5. However, when a member or limb is held within the restraint 10 in the closed state, the portion 20 is in the state of tension so as to restrain the member or limb between the portion 20 and the first and second parts 12 and 14. Also, when the restraint 10 is in the opened state and the parts 12 and 14 pivoted away from each other, the portion 20 is placed under progressively increasing tension. However, the increase in tension only commences after a predetermined annular displacement of the parts 12 and 14

to take up the slack in the portion 20 when the restraint 10 is in the closed state.

In the present embodiment, opposite ends of the band 18 are snaked through slots 24 formed in the parts 12 and 14. Frictional forces hold the ends of the band 18 in place so that the portion 20 can be made of a predetermined length. If necessary, the length can be varied by simply adjusting the threading of one or both ends of the band 18 through the respective slots 24.

10 In an alternate embodiment (not shown), opposite ends of the band 18 are clamped to the parts 12 and 14 by use of clamping plates and screws or bolts.

Each of the parts 12 and 14 are arcuate in shape and in particular, semi-cylindrical. Thus, when the restraint 10 is in the closed state, it substantially resembles a hollow open ended cylinder.

A hollow cylindrical bead 26 is formed along edge 15 of the first part 12 adjacent the second part 14. The bead 26 extends for a substantial portion of, but not the whole, length of the edge 15. A bead 28 is also formed along an adjacent edge 17 of the second part 14. The bead 28 extends for a short length of edge 17 on which it is formed.

The pin 16 passes through both of the beads 26 and 28. One end 30 of the pin 16 is fixed to the bead 28 while the bead 26 is free to pivot about and slide along the pin 16. A bias means in the form of a helical spring 32 is held in compression between head 34 of the pin 16 and face 36 of the bead 26 distant the bead 28. The spring 32 acts to push the beads 26 and 28, and in particular their respective adjacent faces 38 and 40, together.

As seen in Figures 2, 3 and 4, the faces 38 and 40 are of complimentary configuration when the restraint 10 is viewed in the closed position. Indeed, referring to Figure 3, face 38 can be considered as being provided with a semi-circular protrusion 42 while face 40 is provided with a semi-circular recess 44. When the restraint 10 is in the closed position, the protrusion 42 mates with or engages the recess 44 preventing relative rotation of the parts 12 and 14. The faces 38 and 40 are held in this position by the bias of the spring 32.

In order to open the restraint 10, the head 34 of the pin 16 is pushed. This separates the faces 38 and 40 thereby allowing the parts 12 and 14 to be pivoted relative to each other. The pivoting action of the parts 12 and 14 away from each other is enhanced by an elastic band 46 which is connected at opposite ends to the parts 12 and 14 and extends across the back of pin 16 about which the parts 12 and 14 pivot. The elastic band 46 is in a state of tension when the restraint 10 is in the closed state. When the pin 16 is depressed, so as to separate the faces 38 and 40, the band 46 acts to bias the parts 14 and 16 angularly apart to spring open the restraint 10.

When the restraint 10 is in the open state, the protrusion 42 on face 38 bears against a similar protrusion 48 formed on face 40 by the provision of the recess 44. This allows free pivotal movement of the parts 12 and 14 until of course the beads 26 and 28 are angularly offset relative to each other to a position where the protrusion 42 is received by the recess 44.

One end of the band 46 is looped about an elongate handle 50 which extends substantially perpendicularly from an exterior surface of the first part 12. The other end of the band 46 is looped about a post 52 which extends

substantially perpendicularly from the exterior surface of the second part 14.

In the leg holder assembly 54 shown in Figures 5 and 6, two restraints 10 are supported on a spindle 56 coupled to the end of an upright 58. The restraints 10 in Figures 5 and 6 are substantially the same as shown in Figures 1 to 4 with the main exception being that the bead 26 is inboard of the side edges of the part 14 so that the head 34 of the pin 16 sits flush with the side edge of part 14.

10 The spindle 56 is able to pivot about its longitudinal axis 60. Two hollow elongate extensions 62 radiate from the exterior surface of spindle 56 at an internal angle of 120° to each other. Each extension 62 is able to receive the post 52 of one of the restraints 10. A locking system 64  
15 which includes a nut 66 is provided at the end of each extension 62 for clamping the post 52 at various positions and orientations along the extensions 62.

The spindle 56 includes a circular face plate 68 and a transversely extending axle 70. The axle 70 is co-linear with the axis of rotation 60. A detent system 72 is  
20 provided in the spindle 56 to selectively lock the spindle at various angular positions about the axis 60. The locking system 72 comprises a metal ball 74 which is biased by a spring 76 to fit into a number of depressions (not  
25 shown) formed about a bush 78 against which the face plate 68 bears and through which the axle passes.

When using the restraint 10 and leg holder assembly 54, the restraint 10 is placed in the opened state by pushing on the head 34 of the pin 16 to compress spring 32 and push  
30 faces 38 and 40 apart. The elastic band 46 then acts to automatically pivot parts 12 and 14 away from each other about pin 16. Further pivoting of the parts away from each other can be achieved by pushing on the handle 50. The

parts can be placed in an "over-centre" position in which they are pivoted relative to each other by more than 180°.

When in this position, the line of force applied by portion 20 is located below the pin 16 so as to effectively hold the parts 12 and 14 in the over-centre position.

It will be appreciated that as the parts 12 and 14 are pivoted away from each other the tension in portion 20 will progressively increase after an initial degree of pivoting required to take up the slack in portion 20. Generally, the relative lengths and elasticities of the portion 20 and band 46 are arranged so that when the restraint 10 is in the opened state, the band 46 will move parts 12 and 14 away from each other to an extent such that the opening 20 can receive the limb of a sheep without further pivoting being required by the application of force on the handle 50.

To restrain the limb of a sheep, the limb is now passed through opening 22 and pushed against portion 20 of band 18. This causes parts 12 and 14 to pivot toward each other. Provided the length of portion 20 is properly selected and sufficient pushing force is applied to the limb to be restrained, the parts 12 and 14 will pivot toward each other to the extent that protrusion 42 will align with recess 44. The spring 32 will then act to force the faces 38 and 40 together thereby locking the restraint 10 in the closed state. The limb of the sheep is now restrained between the length 20 and the interior surfaces of parts 12 and 14. When the limb is so restrained, portion 20 is under tension so as to squeeze or push the limb against the parts 12 and 14. The sheep is prevented from pulling its limb out of the restraint 10 by the combined action of the tension in the portion 20, and its high friction coefficient.

The spatial position of each restraint 10 on a leg holder assembly 54 can be varied by sliding the post 52 along extension 62; rotating the post 52 about its length; and pivoting the spindle 56 about axis 60. This provides enormous flexibility for restraining the limbs of various animals of different shapes and sizes.

Now that an embodiment of the invention has been described in detail, it will be apparent to those skilled in the relevant arts that numerous modifications and variations may be made without departing from the basic inventive concepts. For example, the faces 40 and 38 can be provided with complimentary configurations other than semicircular such as an X-shaped projection and recess which would allow releasable locking of the parts 12 and 14 together every 90° of angular separation. It will be further appreciated that, switching the restraint 10 from the closed state to the open state can be effected by pushing on the handle 50 in a direction parallel to the pin 16 as well as pushing on the head 34 of pin 16. Also, the parts 12 and 14 are shown as being arcuate so as to form a cylindrical shape when the restraint 10 is in the closed position. However, the parts 12 and 14 can be of other shapes provided that when the restraint 10 is in the closed position they form a substantially closed shape. It is not essential that the parts 12 and 14 completely meet when restraint 10 is in the locked position. All that is required is that any spacing between the edges of plates 12 and 14 not be big enough to allow the escape of a member held within the restraint 10. Finally, it is again stressed that while the present invention was developed with a view to restraining the limbs of sheep, the structure and concept of the invention is equally applicable to restraining or holding the limbs of other animals, or any other object or thing. Indeed, the restraint could be used as part of a workbench for tradesman for holding pipes or tools or otherwise acting as a "extra hand".

All such modifications and variations are deemed to be within the scope of the present invention the nature of which is to be determined from the foregoing description and the appended claims.

1  
2  
3  
4  
5  
6  
7  
8  
9  
10  
11  
12  
13  
14  
15  
16  
17  
18  
19  
20  
21  
22  
23  
24  
25  
26  
27  
28  
29  
30  
31  
32  
33  
34  
35  
36  
37  
38  
39  
40  
41  
42  
43  
44  
45  
46  
47  
48  
49  
50  
51  
52  
53  
54  
55  
56  
57  
58  
59  
60  
61  
62  
63  
64  
65  
66  
67  
68  
69  
70  
71  
72  
73  
74  
75  
76  
77  
78  
79  
80  
81  
82  
83  
84  
85  
86  
87  
88  
89  
90  
91  
92  
93  
94  
95  
96  
97  
98  
99  
100

1  
2  
3  
4  
5  
6  
7  
8  
9  
10  
11  
12  
13  
14  
15  
16  
17  
18  
19  
20  
21  
22  
23  
24  
25  
26  
27  
28  
29  
30  
31  
32  
33  
34  
35  
36  
37  
38  
39  
40  
41  
42  
43  
44  
45  
46  
47  
48  
49  
50  
51  
52  
53  
54  
55  
56  
57  
58  
59  
60  
61  
62  
63  
64  
65  
66  
67  
68  
69  
70  
71  
72  
73  
74  
75  
76  
77  
78  
79  
80  
81  
82  
83  
84  
85  
86  
87  
88  
89  
90  
91  
92  
93  
94  
95  
96  
97  
98  
99  
100

1  
2  
3  
4  
5  
6  
7  
8  
9  
10  
11  
12  
13  
14  
15  
16  
17  
18  
19  
20  
21  
22  
23  
24  
25  
26  
27  
28  
29  
30  
31  
32  
33  
34  
35  
36  
37  
38  
39  
40  
41  
42  
43  
44  
45  
46  
47  
48  
49  
50  
51  
52  
53  
54  
55  
56  
57  
58  
59  
60  
61  
62  
63  
64  
65  
66  
67  
68  
69  
70  
71  
72  
73  
74  
75  
76  
77  
78  
79  
80  
81  
82  
83  
84  
85  
86  
87  
88  
89  
90  
91  
92  
93  
94  
95  
96  
97  
98  
99  
100

1  
2  
3  
4  
5  
6  
7  
8  
9  
10  
11  
12  
13  
14  
15  
16  
17  
18  
19  
20  
21  
22  
23  
24  
25  
26  
27  
28  
29  
30  
31  
32  
33  
34  
35  
36  
37  
38  
39  
40  
41  
42  
43  
44  
45  
46  
47  
48  
49  
50  
51  
52  
53  
54  
55  
56  
57  
58  
59  
60  
61  
62  
63  
64  
65  
66  
67  
68  
69  
70  
71  
72  
73  
74  
75  
76  
77  
78  
79  
80  
81  
82  
83  
84  
85  
86  
87  
88  
89  
90  
91  
92  
93  
94  
95  
96  
97  
98  
99  
100

THE CLAIMS DEFINING THE INVENTION ARE AS FOLLOWS:-

1. A restraint comprising:  
first and second parts pivotally coupled together, said restraint having a closed state in which said first and second parts are releasably locked in a mutually facing relationship and, an opened state in which said first and second parts can be pivoted relative to each other; and,  
an elastic band connected between said parts and having a portion which extends across an opening in said restraint that can be formed between said parts when said restraint is in said opened state;  
whereby, in use, when said restraint is in said opened state a member can be pushed against said portion causing said parts to pivot toward each other until said restraint is in said closed state thereby restraining said member between said elastic band and said first and second parts.
2. A restraint according to claim 1, wherein said elastic band is provided with a surface having a relatively high friction coefficient to resist withdrawal of said member in a direction perpendicular to the length of said portion.
3. A restraint according to claim 1 or 2, wherein said portion is of a length so as to be relaxed when said restraint is in said closed state with no member restrained therein and to be under progressively increasing tension as said first and second parts pivot away from each other beyond a predetermined angular displacement.
4. A restraint according to any one of claims 1 to 3, wherein said portion is further dimensioned so as to be in tension when said restraint is in said closed state and

a member is restrained between said elastic band and said first and second parts.

5 5. A restraint according to any one of claims 1 to 4, said restraint further comprises releasable locking means for releasably locking said restraint in said closed state.

10 6. A restraint according to claim 5, wherein said releasable locking means comprises a first face on said first part and a second face on said second part of a configuration complementary to said first face, wherein when said restraint is in said closed state, said first and second faces engage each other to prevent relative pivotal movement of said first and second parts thereby locking said restraint in said closed state.

15 7. A restraint according to claim 6, wherein said releasable locking means further comprises first bias means for biasing said faces together and holding said faces in engagement when said restraint is in said closed state.

20 8. A restraint according to claim 7, wherein said releasable locking means further comprises manually operable means for separating said faces against said bias means to allow said first and second parts to pivot relative to each other thereby placing said restraint in said opened state.

25 9. A restraint according to any one of claims 1 to 8, wherein said restraint further comprises second bias means for biasing said parts to pivot away from each other whereby, in use, when the state of said restraint is switched from said closed state to said opened state, said  
30 second bias means causes said first and second parts to pivot away from each other.

10. A restraint according to claim 9, wherein said  
second bias means comprises an elastic band or strap  
connected at opposite ends to respective ones of said first  
and second parts and extending across an axis about which  
5 said parts pivot.

11. A restraint according to any one of claims 8 to  
10, wherein, said manually operable means comprises a pin  
which extends collinearly with said axis, said pin being  
fixed to one of said parts with the other part movable  
10 about and along said pin.

12. A restraint according to claim 11, wherein said  
first bias means acts between an end of said pin and the  
other of said parts.

13. A restraint according to any one of claims 1 to  
12, wherein each of said parts is arcuate in shape.  
15

14. A restraint substantially as herein described  
with reference to and as illustrated in the accompanying  
drawings.

Dated this 23rd day of May 1997.

20 CHAIN SHEARING LTD  
By its Patent Attorneys:

GRIFFITH HACK  
Fellows Institute of Patent  
Attorneys of Australia.

ABSTRACT

A restraint 10 comprises first and second parts 12 and 14 which are pivotally coupled together about pin 16. The restraint 10 has a closed state in which the first and second parts 12 and 14 are releasably locked in mutually facing relationship, and an opened state in which the first and second parts, 12 and 14, can be pivoted relative to each other. An elastic band 18 is connected between the first and second parts 12, 14 and has a portion 20 which extends across an opening 22 formed between the first and second parts 12, 14 when the restraint 10 is in the opened state. In use, when the restraint is in the opened state, a member such as the hind leg of a sheep, can be pushed against the portion 20 of the elastic band 18 causing the parts 12 and 14 to pivot toward each other until the restraint 10 enters the closed state thereby restraining the legs of the sheep between the portion 20 and the first and second parts 12 and 14.



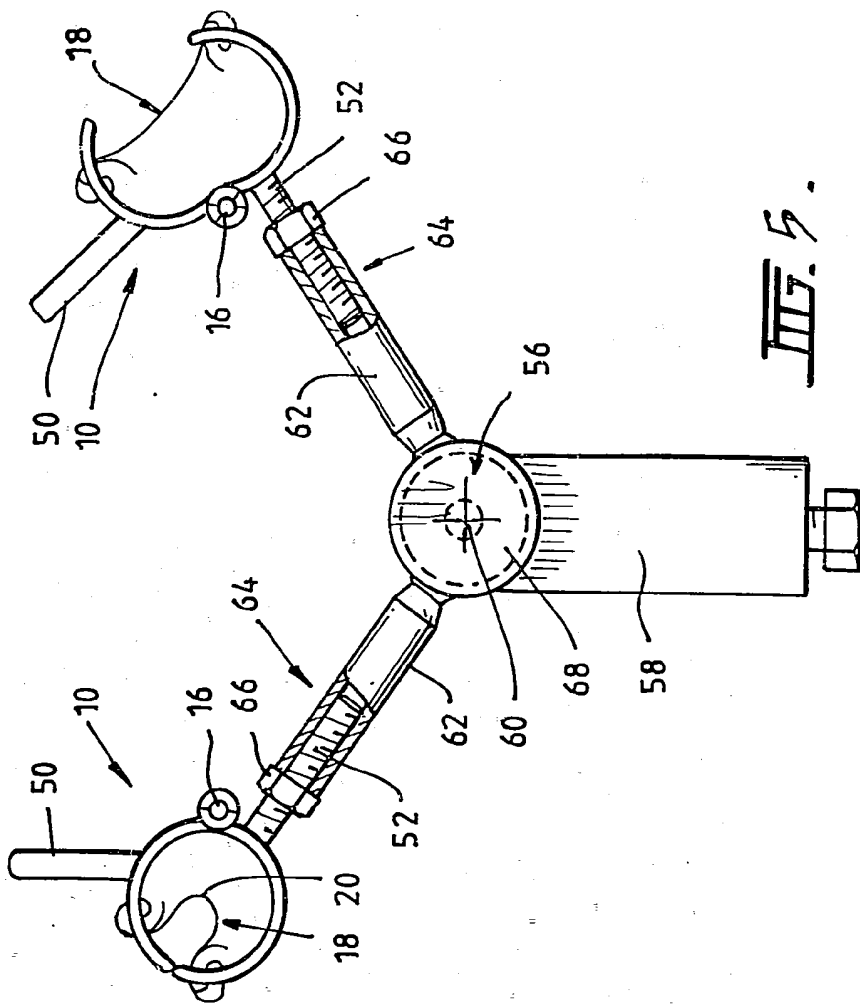

FIG. 5.

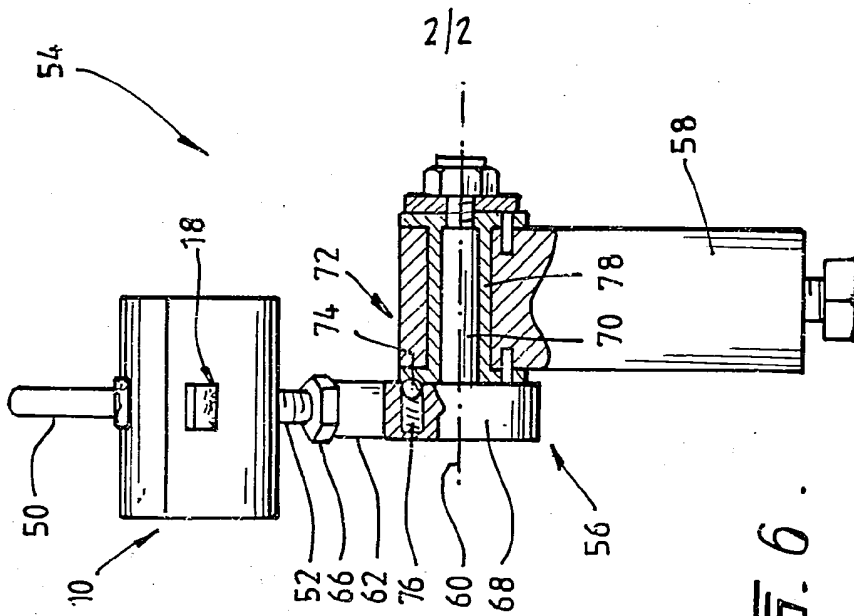

FIG. 6.