

(12) PATENT APPLICATION
(19) AUSTRALIAN PATENT OFFICE

(11) Application No. **AU 199739890 A1**
(10) Patent No. **730019**

(54) Title
Animal processing conveyor

(51) International Patent Classification(s)
A01K 014/00 B65G 015/58
A22B 007/00 B65G 015/60
B65G 015/28 B65G 017/02
B65G 015/52 B65G 017/38

(21) Application No: **199739890** (22) Date of Filing: **1997.10.01**

(30) Priority Data

(31) Number	(32) Date	(33) Country
PO2753	1996.10.03	AU

(43) Publication Journal Date: **1998.04.09**

(44) Accepted Journal Date: **2001.02.22**

(71) Applicant(s)
Chain Shearing Ltd

(54) Inventor(s)
Fred Wybrow

PATENT REQUEST: STANDARD PATENT

We, Chain Shearing Ltd being the person(s) identified below as the Applicant, request the grant of a patent to the person identified below as the Nominated Person, for an invention described in the accompanying standard complete specification.
Full application details follow.

[71] Applicant:
Address: CHAIN SHEARING LTD
PASTORAL HOUSE
1/277 GREAT EASTERN HIGHWAY
BELMONT WA 6104

[70] Nominated Person:
Address: CHAIN SHEARING LTD
PASTORAL HOUSE
1/277 GREAT EASTERN HIGHWAY
BELMONT WA 6104

[54] Invention Title: **ANIMAL PROCESSING CONVEYOR**

[72] Name(s) of actual inventor(s): FRED WYBROW

[74] Address for service in Australia:
GRIFFITH HACK, Patent and Trade Mark Attorneys, 256 Adelaide Tce, Perth
6000, Western Australia, AUSTRALIA. Attorney Code: HP

ASSOCIATED PROVISIONAL APPLICATION(S) DETAILS

[60] Application Number(s) and Date(s)

Australian Provisional Patent Application No. PO 2753 filed on 3 October 1997

Drawing number recommended to accompany the abstract Figure 4

Dated this 1st day of October 1997.

CHAIN SHEARING LTD

GRIFFITH HACK

Patent Attorneys for and
on behalf of the Applicant



AU9739890

(12) PATENT ABSTRACT (11) Document No. AU-A-39890/97
(19) AUSTRALIAN PATENT OFFICE

- (54) Title
ANIMAL PROCESSING CONVEYOR
- International Patent Classification(s)
(51)⁶ A01K 014/00 A22B 007/00 B65G 015/28 B65G 015/52
B65G 015/58 B65G 015/60 B65G 017/02 B65G 017/38
- (21) Application No. : 39890/97 (22) Application Date : 01/10/97
- (30) Priority Data
- (31) Number (32) Date (33) Country
PO2753 03/10/96 AU AUSTRALIA
- (43) Publication Date : 09/04/98
- (71) Applicant(s)
CHAIN SHEARING LTD
- (72) Inventor(s)
FRED WYBROW
- (74) Attorney or Agent
GRIFFITH HACK , 256 Adelaide Terrace, PERTH WA 6000

(57) An animal processing conveyor (10) for the production line processing of a live animal comprises a conveyor system (12) which includes a flexible belt (14) arranged in a continuous loop on which the animal is directly supported. Disposed along an upper run of the conveyor system (12) is a plurality of operator stations (18A - 18F) at which individual operators can carry out process steps on the animal. Conveyor system (12) includes an endless chain (24) which is parallel to and inside of the flexible belt (14). Endless chain (24) includes a plurality of horizontally disposed slats (26) that extend perpendicular to the length of belt (14). Each slat (26) is formed with a central channel (28) for cradling an animal when supported on the overlying flexible belt (14). First leg holders (16) are attached in the channel portion (28) of selected ones of the slats (26) and extend through holes formed in the flexible belt (14) for restraining the limbs of the live animal. In use an animal such as a sheep is supported on flexible belt (14) at a first station (18A), and has its limbs restrained by a leg holder (16). The sheep is then transported by conveyor system (12) sequentially to each of the operator stations (18A - 18F) where respective operators can perform predetermined processing steps.

AUSTRALIA

PATENTS ACT 1990

COMPLETE SPECIFICATION FOR A

STANDARD PATENT

Name of Applicant: CHAIN SHEARING LTD

Address of Applicant: PASTORAL HOUSE
1/277 GREAT EASTERN HIGHWAY
BELMONT WA 6104

Actual Inventor: FRED WYBROW

Address for Service: Griffith Hack & Co.
256 Adelaide Terrace (6 Floor)
PERTH WA 6000

Standard Complete Specification for the invention entitled:

ANIMAL PROCESSING CONVEYOR

Details of Associated Provisional Applications:

Australian Provisional Patent Application No. PO 2753 dated 3 October 1996

The following is a full description of this invention, including the best method of performing it known to me:-

ANIMAL PROCESSING CONVEYOR

The present invention relates to an animal processing conveyor and in particular, but not exclusively, to a defleecing conveyor for sheep.

5 Applicant's Australian patent application No. 28426/95 discloses a conveyor type production line for processing animals and in particular for shearing sheep. The apparatus disclosed comprises a number of supports each of which supports one sheep. These supports are coupled to an
10 endless loop conveyor and transport the sheep to a number of successive stations for defleecing. The supports and associated hardware for connecting them to the conveyor form a substantial cost component of the overall apparatus. Additionally, the supports could present a safety hazard to
15 users of the apparatus. Further, in one of the embodiments shown in the aforementioned patent application, the supports are transported by an overhead conveyor system which results in the overall apparatus being of quite substantial size and thus requiring, in many instances, the
20 need for purpose built sheds for housing.

It is an object of the present invention to provide a simplified animal conveyor system which can be used for the production line and processing of an animal.

25 According to the present invention there is provided an animal processing conveyor for facilitating the production line processing of a live animal comprising:

a conveyor system including a flexible belt arranged in a continuous loop on which a live animal is directly supported;

30 means for restraining at least one of the limbs of said live animal, said means coupled to said conveyor system; and,

a plurality of operator stations disposed along at least a portion of said conveyor system at each of which an operator can carry out a process step on said live animal;

5 whereby, in use, a live animal can be supported on said conveyor system and transported sequentially to said operator stations at which at least one of the live animal's limbs is restrained by said means and where
10 respective operators can carry out predetermined processing steps.

Preferably said conveyor system comprises an endless chain extending substantially parallel to and on an inside of the continuous loop formed by said flexible belt, said endless
15 chain including a plurality of horizontally disposed slats which extend perpendicular to the direction of the length of said flexible belt, said slats provided with a central channel or depression so that, in use, an animal supported
20 on said flexible belt is cradled in said central channel or depression of one or more of the slats underlying said flexible belt.

Preferably said flexible belt and endless chain are driven together.

Preferably said means for restraining at least one limb comprises a first limb restraint, said first limb restraint
25 being coupled to said endless chain and extending through said flexible belt for restraining a first one or first set of limbs so that in use said animal is transported to successive stations by said conveyor system with a first one or first set of limbs being restrained.

30 Preferably said conveyor system further comprises a frame about which said flexible belt and endless chain travel and wherein said means for restraining at least one limb further comprises a second limb restraint which is

connected to said frame and moveable between a first position in which it restrains movement of a second one or second set of limbs and a second position in which said second one or second set of limbs is unrestrained.

5 Preferably said second limb restraint comprises a bar which when in said first position extends substantially perpendicularly across said flexible belt and at a distance above said flexible belt to bear against said second one or second set of limbs.

10 Preferably said second limb restraint is adapted so that the distance of said bar above said flexible belt when in the first position can be adjusted.

15 Preferably said animal processing conveyor further comprises switching means for controlling said conveyor system, said switching means comprising a plurality of separate switches, individual ones of which are located at each operator station and arranged so that said switching means enables said conveyor system to transport an animal only when all of said switches are caused to be in the same state at the same time by the respective operators.

20 Preferably, each switch is operated by a push bar or pressure sensor located at each operator station against which each operator can bear, said switching means further arranged to cause said conveyor system to transport an animal from one operator station to another only when each and every operator is not contact with said push bar or pressure sensor.

25 An embodiment of the present invention will now be described by way of example only, with reference to the accompanying drawings in which:
30

Figure 1 is a conceptual drawing from the top of an embodiment of the animal handling system;

Figure 2 is a side view of the system shown in Figure 1;

5 Figure 3 is an isometric view of a slat incorporated in a conveyor system of the system shown in Figures 1 and 2; and,

Figure 4 is a view of section A-A of the system shown in Figure 1.

10 As shown in the accompanying drawings, an animal processing conveyor 10 for facilitating the production line processing of a live animal (not shown) comprises a conveyor system 12 which includes a flexible belt 14 arranged in a continuous loop on which the animal is directly supported. Also included is means for restraining at least one of the limbs
15 of the animal. The means for restraining the limbs includes first and second restraints. The first restraint is shown generally as item 16 in Figure 4 and travels with the flexible belt 14. The first restraint 16 is adapted to restrain the hind legs of the animal (typically a sheep).
20 Restraint 16 is ideally in the form of that described in Applicant's corresponding provisional application No. PO 0291, the contents of which is incorporated herein by way of reference.

25 Disposed along an upper run of the conveyor system 12 is a plurality of operator stations 18A-18F (referred to in general as "operator stations 18") at which individual operators can carry out process steps on the sheep. The operator stations 18 are essentially predetermined work areas along platforms 20 and 22 which are disposed on
30 opposite sides of the conveyor system 12.

In broadest terms, when the process conveyor 10 is in use, a sheep is supported on the flexible belt 14 at a first operator station 18A, its limbs restrained by restrain 16 and then the sheep transported by the conveyor system 12 sequentially to each of the operator stations 18A-18F. At each of the operator stations 18, an operator can perform a particular or predetermined processing step. In particular, in the present embodiment, the processing steps entail various aspects of defleecing a sheep.

10 The sheep is initially loaded onto or presented near the first station 18A by use of a conventional "VE" machine which does not form part of the present invention.

The conveyor system 12 further includes an endless chain 24 which extends substantially parallel to and inside of the continuous loop formed by the flexible belt 14. The endless chain 24 includes a plurality of horizontally disposed slats 26 which extend perpendicular to the length of the flexible belt 14. As shown most clearly in figure 3, each horizontal slat 26 is formed with a central channel or depression 28 for cradling a sheep when supported on the overlying flexible belt 14. The first leg holders 16 are bolted or otherwise attached in the channel portion 28 of selected ones of the slats 26 and extend through holes formed in the flexible belt 14.

25 Referring to figures 1 and 2, the flexible belt 14 travels about four pairs of rotatable cylinders 30. The chain 24 also travels about four pairs of sprocket wheels 32. Each pair of sprocket wheels 32 is coaxially arranged with a corresponding pair of cylinders 30. A motor 34 drives one coaxial set of cylinders 30 and sprockets 32 for effecting travel of the flexible belt 14 and chain 24. By virtue of this arrangement, the flexible belt 14 and chain 24 are driven together.

Referring to Figure 4, it can be seen that the conveyor system 12 includes a frame 36 about which the flexible belt 14 and endless chain 24 travel. Also attached to the frame 36 at spaced apart locations along its length is a series of second limb restraints 38. The purpose of the second limb restraints 38 is to restrain the movement of the front limbs of the sheep. The second limb restraint 38 is movable between a first position in which it restrains movement of the front limbs of the sheep and a second position in which the front limbs are unrestrained.

In one form, the second limb restraint 38 comprises a bar 40 which extends perpendicularly across the flexible belt 14. One end of the bar 40 is attached to a rod 42 which is coupled to a pivot axis 44. The pivot axis 44 extends from the frame 36 and is arranged so that the bar 40 can be pivoted or swung in an arc above the flexible belt 14. The lowest point in the arc corresponds with the first position. When in this position, the bar 40 bears against the front limbs of the sheep. A releasable locking system (not shown) is also provided to releasably lock the bar 40 in the first position. When in the second position, the bar 40 is disposed above the flexible belt 14 at a height so as to allow any sheep on the flexible belt 14 as well as the first restraints 16 to pass thereunder. The releasable locking system can be further arranged so as to allow variation of the first position of the bar 40 so as to restrain the limbs of sheep of different sizes.

The animal processing conveyor 10 also includes a switching means for controlling conveyor system 12. The switching means includes a plurality of switches with associated push bars 48A-48F which are located at corresponding operator stations 18A-18F respectively. The output of each of the switches 48, forms an input to a controller 46 which in turn is coupled to and controls the motor 34. The switches 48 and controller 46 are arranged so that the motor 34 is only

able to drive the cylinders 30 and sprockets 32 when each of the switches 48 is in the same state, ie. either all ON or all OFF. In use, when each of the operators (not shown) stands back from or otherwise does not apply any pressure on the push bars the controller 46 enables the motor 34 to drive the flexible belt 14 and chain 24. However, if any one or more operator applies pressure or is applying pressure to one of the push bars the controller 46 will disable the motor 34 so that the flexible belt 14 and chain 24 remain stationary. In this way, a sheep only proceeds to a subsequent operator station once each and every operator has completed their predetermined process step and has disengaged from the push bar.

Each operator station 18 can also be provided with appropriate tools or apparatus so that the operator can form the predetermined process step. In the case of the conveyor 10 being used for defleecing the sheep, each operator station 18 can be provided with a set of shears and shears drive or power unit 50.

When in use for the purpose of defleecing a sheep, a first sheep is conveyed by a VE machine (not shown) to the first operator station 18A. At this station, a sheep is supported on its back on the flexible belt 14 cradled in the channel 28 of the underlying slats 26. The rear legs of the sheep are then placed in the first restraint 16. To restrain the front legs of the sheep, the bar 40 is swung down and locked in the first position in which it bears against the front legs of the sheep. The operator at station 18A can then perform its predetermined process step. The operator can then stand away from the push bar of switch 48A and, assuming all other operators are also away from corresponding push bars the controller 46 will enable the motor 34 so as to drive the cylinders 30 and sprockets 32 to transport the sheep towards station 18B.

When at this station, the operator at that station rests or leans on the push bar of switch 48B. This will cause the controller 46 to disenable the motor 34 thereby stopping the movement and travel of the flexible belt 14. The operator at station 18B can then perform its predetermined process step. At the same time, the operator of station 18A is also performing its processing step on another sheep loaded onto the conveyor 10. In a similar manner, further sheep are loaded onto the conveyor 10 and advanced therealong. An alighting system (not shown) is provided near station 18F for removing sheep from the conveyor 10 after the operator at the station has completed its processing step. At the end of this step, the sheep would be completely defleeced. The fleece may then be conveyed onto a fleece spreader of the type described in Applicant's co-pending Australian patent application No. PN 9796.

Now that an embodiment of the invention has been described in detail, it will be apparent to those skilled in the relevant arts that numerous modifications and variations may be made without departing from the basic inventive concepts. For example, the first and second limb restraints 16 and 38 respectively, can take any form appropriate to perform their intended function of restraining movement of the limbs of a live animal. Also, the push bars associated with switches 48 can instead be placed on the platforms 20 and 22 respectively so that an operator can stand on them or step off them as the case may be to effect operation of the motor 34 and movement of the flexible belt 14. Further, while the present invention has been described with reference to defleecing a sheep, it may be used for conducting other processes and on other animals. All such modifications and variations are deemed to be within the scope of the present invention, the nature of which is to be determined from the foregoing description and the appended claims.

THE CLAIMS DEFINING THE INVENTION ARE AS FOLLOWS:

1. An animal processing conveyor for facilitating the production line processing of a live animal comprising:
a conveyor system including a flexible belt
5 arranged in a continuous loop on which a live animal is directly supported;

means for restraining at least one of the limbs of said live animal, said means coupled to said conveyor system; and,

10 a plurality of operator stations disposed along at least a portion of said conveyor system at each of which an operator can carry out a process step on said live animal;

15 whereby, in use, a live animal can be supported on said conveyor system and transported sequentially to said operator stations at which at least one of the live animal's limbs is restrained by said means and where respective operators can carry out predetermined processing steps.

20 2. An animal processing conveyor according to claim 1 wherein, said conveyor system comprises an endless chain extending substantially parallel to and on an inside of the continuous loop formed by said flexible belt, said endless chain including a plurality of horizontally disposed slats
25 which extend perpendicular to the direction of the length of said flexible belt, said slats provided with a central channel or depression so that, in use, an animal supported on said flexible belt is cradled in said central channel or depression of one or more of the slats underlying said
30 flexible belt.

3. An animal processing conveyor according to claim 2 wherein, said flexible belt and endless chain are driven together.

4. An animal processing conveyor according to claim 2 or 3 wherein, said means for restraining at least one limb comprises a first limb restraint, said first limb restraint being coupled to said endless chain and extending
5 through said flexible belt for restraining a first one or first set of limbs so that in use said animal is transported to successive stations by said conveyor system with a first one or first set of limbs being restrained.

5. An animal processing conveyor according to any
10 one of claims 2 to 4 further comprising, a frame about which said flexible belt and endless chain travel and wherein said means for restraining at least one limb further comprises a second limb restraint which is connected to said frame and moveable between a first
15 position in which it restrains movement of a second one or second set of limbs and a second position in which said second one or second set of limbs is unrestrained.

6. An animal processing conveyor according to claim 5 wherein, said second limb restraint comprises a bar which
20 when in said first position extends substantially perpendicularly across said flexible belt and at a distance above said flexible belt to bear against said second one or second set of limbs.

7. An animal processing conveyor according to claim 6 wherein, said second limb restraint is adapted so that
25 the distance of said bar above said flexible belt when in the first position can be adjusted.

8. An animal processing conveyor according to any
30 one of claims 1 to 7 further comprising, switching means for controlling said conveyor system, said switching means comprising a plurality of separate switches, individual ones of which are located at each operator station and arranged so that said switching means enables said conveyor

system to transport an animal only when all of said switches are caused to be in the same state at the same time by the respective operators.

5 9. An animal processing conveyor according to claim 8 wherein each switch is operated by a push bar or pressure sensor located at each operator station against which each operator can bear, said switching means further arranged to cause said conveyor system to transport an animal from one operator station to another only when each and every operator is not contact with said push bar or pressure sensor.

10 10. An animal processing conveyor substantially as herein described with reference to and as illustrated in the accompanying drawings.

15 Dated this 1st day of October 1997.

CHAIN SHEARING LTD

By its Patent Attorneys:
GRIFFITH HACK & CO.

20 Fellows Institute of Patent Attorneys of Australia.

ABSTRACT

An animal processing conveyor (10) for the production line processing of a live animal comprises a conveyor system (12) which includes a flexible belt (14) arranged in a continuous loop on which the animal is directly supported. Disposed along an upper run of the conveyor system (12) is a plurality of operator stations (18A - 18F) at which individual operators can carry out process steps on the animal. Conveyor system (12) includes an endless chain (24) which is parallel to and inside of the flexible belt (14). Endless chain (24) includes a plurality of horizontally disposed slats (26) that extend perpendicular to the length of belt (14). Each slat (26) is formed with a central channel (28) for cradling an animal when supported on the overlying flexible belt (14). First leg holders (16) are attached in the channel portion (28) of selected ones of the slats (26) and extend through holes formed in the flexible belt (14) for restraining the limbs of the live animal. In use an animal such as a sheep is supported on flexible belt (14) at a first station (18A), and has its limbs restrained by a leg holder (16). The sheep is then transported by conveyor system (12) sequentially to each of the operator stations (18A - 18F) where respective operators can perform predetermined processing steps.

U.S. PATENT OFFICE

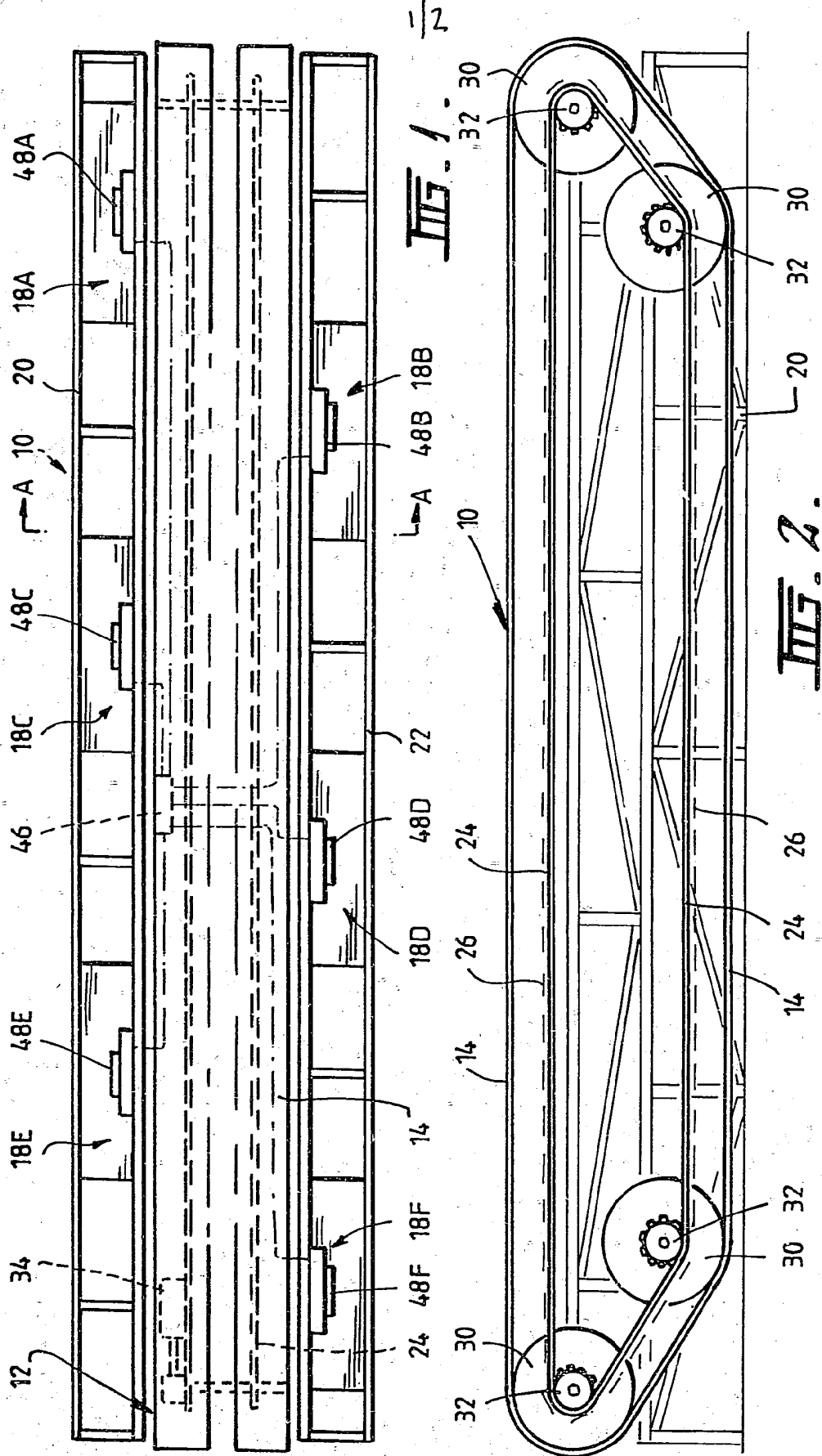

39890/97

2/2

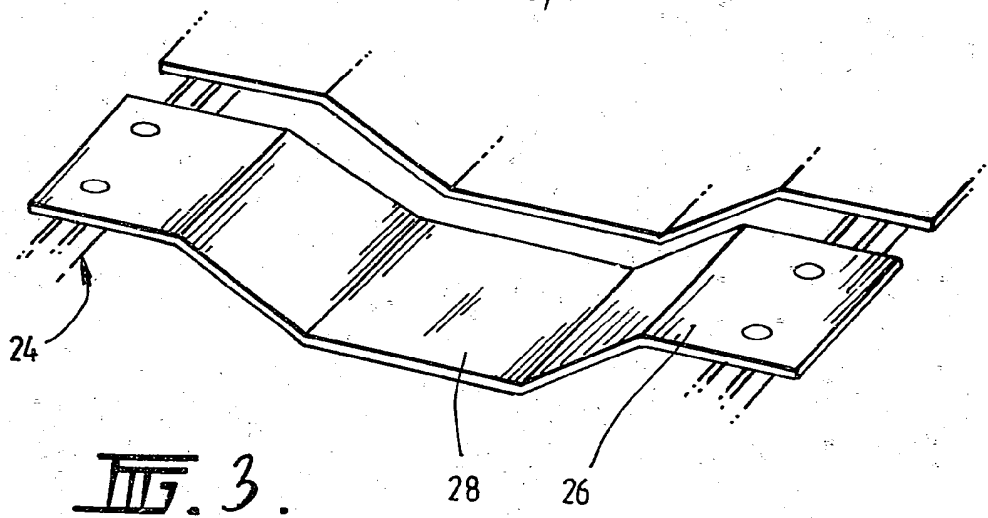

FIG. 3.

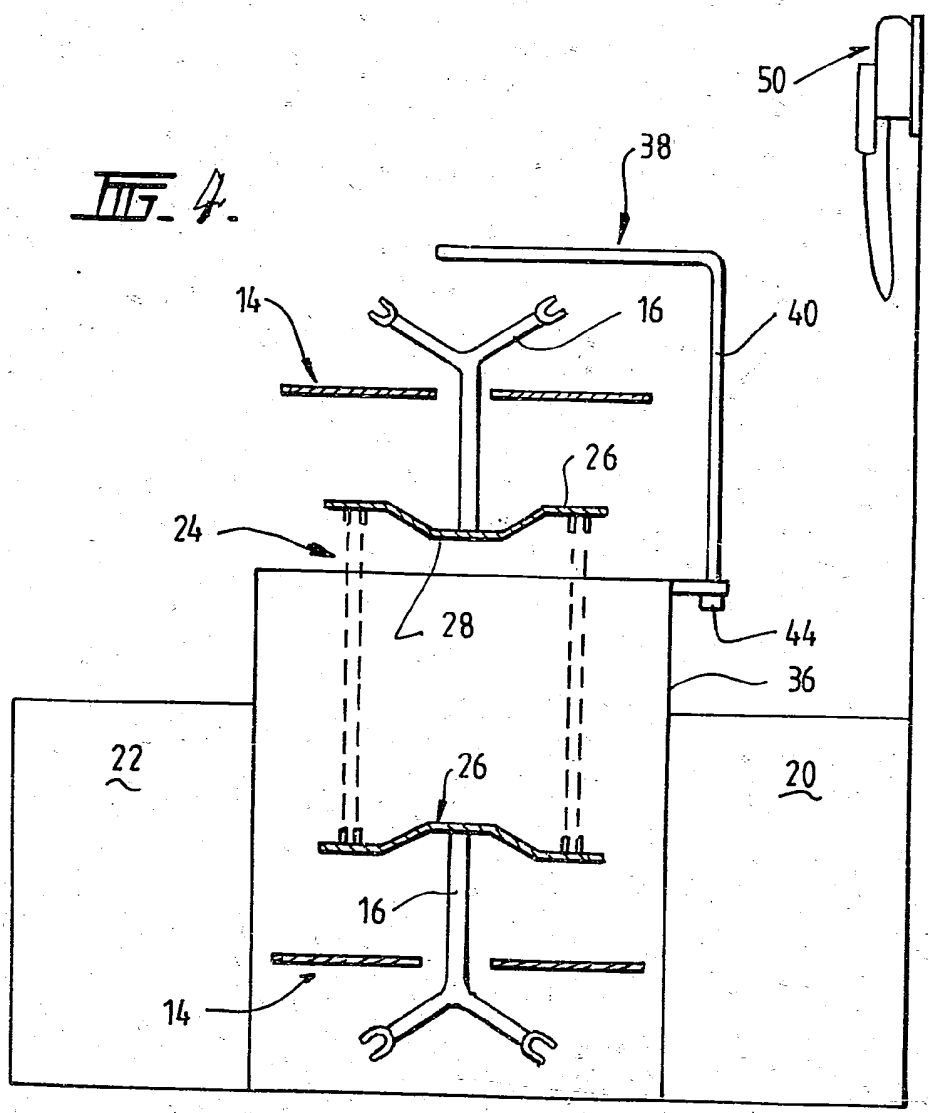

FIG. 4.