

(12) PATENT APPLICATION
(19) AUSTRALIAN PATENT OFFICE

(11) Application No. **AU 199720141 A1**
(10) Patent No. **724484**

(54) Title
Apparatus for spreading a sheet-like article

(51) International Patent Classification(s)
B65G 035/00 B65G 047/00
B65G 041/00 B65H 023/18

(21) Application No: **199720141** (22) Date of Filing: **1997.05.08**

(30) Priority Data

(31) Number (32) Date (33) Country
PN9796 1996.05.10 AU

(43) Publication Journal Date: **1997.11.13**

(44) Accepted Journal Date: **2000.09.21**

(71) Applicant(s)
Chain Shearing Ltd

(54) Inventor(s)
Fred Wybrow; Rhonda Wybrow

AUSTRALIA
Patents Act 1990

**PATENT REQUEST: STANDARD PATENT
and
NOTICE OF ENTITLEMENT**

We, CHAIN SHEARING LTD, being the person(s) identified below as the Applicant, request the grant of a patent to the person identified below as the Nominated Person, for an invention described in the accompanying standard complete specification.

Full application details follow.

[71] Applicant: CHAIN SHEARING LTD

Address: Pastoral House
1/277 Great Eastern Highway
Belmont, Western Australia
Australia 6104

[70] Nominated Person: Applicant

Address:

[54] Invention Title: APPARATUS FOR SPREADING A SHEET-LIKE ARTICLE

[72] Name(s) of actual inventor(s):

FRED and RHONDA WYBROW

[74] Address for service in Australia:

GRIFFITH HACK, Patent and Trade Mark Attorneys, 256 Adelaide Tce, Perth
6000, Western Australia, AUSTRALIA. Attorney Code: HP

ASSOCIATED PROVISIONAL APPLICATION(S) DETAILS

[60] Application Number(s) and Date(s)

PN 9796 filed 10 May 1996

We, CHAIN SHEARING LTD

of Pastoral House
1/277 Great Eastern Highway
Belmont, Western Australia
Australia 6104

being the applicant in respect of this Application state the following:-

The person(s) nominated for the grant of the patent:

would be entitled to have assigned to it a patent granted to any of the actual inventors in respect of the said invention.

The person(s) nominated for the grant of the patent:

is the applicant of the provisional application listed on the patent request form.

Drawing number recommended to accompany the abstract Figure 1.

Dated this 8th day of May 1997.

CHAIN SHEARING LTD

GRIFFITH HACK



Patent Attorneys for and
on behalf of the Applicant



AU9720141

(12) PATENT ABSTRACT (11) Document No AU-A-20141/97
(19) AUSTRALIAN PATENT OFFICE

- (54) Title
APPARATUS FOR SPREADING A SHEET-LIKE ARTICLE
- International Patent Classification(s)
(51)^e B65G 035/00 B65G 041/00 B65G 047/00 B65H 023/18
- (21) Application No. : 20141/97 (22) Application Date : 08/05/97
- (30) Priority Data
- (31) Number (32) Date (33) Country
PN9796 10/05/96 AU AUSTRALIA
- (43) Publication Date : 13/11/97
- (71) Applicant(s)
CHAIN SHEARING LTD
- (72) Inventor(s)
FRED WYBROW; RHONDA WYBROW
- (74) Attorney or Agent
GRIFFITH HACK, 256 Adelaide Terrace, PERTH WA 6000
- (57) Claim

1. An apparatus for spreading a sheet-like article comprising:
- a conveyor belt arranged for transporting said sheet-like article in a first direction at a first speed;
 - a support surface disposed at or below the level of said conveyor belt to which said sheet-like article can pass; and,
- means for effecting relative movement between said support surface and said conveyor belt at a second speed which is greater than said first speed;
- whereby, in use, when said sheet-like article is disposed on said conveyor belt and said conveyor belt operated to transport said sheet-like article in a first direction so as to commence to pass onto said support surface, said means can be simultaneously operated to cause said relative movement between said conveyor belt and said support surface so that said sheet-like article is laid out on said support surface at a greater speed than it is paid out from said conveyor belt thereby spreading said sheet-like article.

AUSTRALIA

PATENTS ACT 1990

COMPLETE SPECIFICATION FOR A
STANDARD PATENT

Name of Applicant:

CHAIN SHEARING LTD

Address of Applicant:

Pastoral House
1/277 Great Eastern Highway
Belmont, Western Australia
Australia 6104

Actual Inventor:

Fred and Rhonda WYBROW

Address for Service:

Griffith Hack, Patent & Trade Mark
Attorneys of 256 Adelaide Terrace (6th
Floor), Perth, Western Australia,
Australia 6000

Standard Complete Specification for the invention entitled:

APPARATUS FOR SPREADING A SHEET-LIKE ARTICLE

Details of Associated Provisional Applications:

PN 9796 filed 10 May 1996

The following is a full description of this invention, including the best method of performing it known to me:-

APPARATUS FOR SPREADING A SHEET-LIKE ARTICLE

The present invention relates to an apparatus for spreading a sheet-like article and, in particular, but not exclusively, to an apparatus for spreading a fleece.

5 The motivation for the present invention is derived from the Applicant's prior innovations relating to wool harvesting systems and techniques as described in Australian patent application nos. 28426/95 and 18914/97, the contents of which are incorporated herein by way of
10 reference.

In the aforementioned innovations, the wool from a sheep is harvested in a production line manner by a plurality of wool harvesters with the fleece, once detached, being transported by a conveyor belt for classing and skirting.
15 At present however, the fleece must be physically picked up from the conveyor belt and then spread by throwing onto a table for further processing.

It is an object of the present invention to provide an apparatus which can automatically spread a fleece thus
20 eliminating the need for a person to pick up the fleece and physically transport it and spread it on to a table. However, it will be appreciated that the apparatus can be used for spreading other types of sheet-like articles.

According to the present invention there is provided an
25 apparatus for spreading a sheet-like article comprising:

a conveyor belt arranged for transporting said sheet-like article in a first direction at a first speed;
a support surface disposed at or below the level
of said conveyor belt to which said sheet-like article can
30 pass; and,

means for effecting relative movement between said support surface and said conveyor belt at a second

speed which is greater than said first speed;

5 whereby, in use, when said sheet-like article is disposed on said conveyor belt and said conveyor belt operated to transport said sheet-like article in a first direction so as to commence to pass onto said support surface, said means can be simultaneously operated to cause said relative movement between said conveyor belt and said support surface so that said sheet-like article is laid out on said support surface at a greater speed than it is paid out from said conveyor belt thereby spreading said sheet-like article.

10 Preferably said means effects movement of said support surface relative to said conveyor belt in a second direction opposite to said first direction so that said sheet-like article is inverted when laid out on said support surface.

15 In an alternate embodiment, said second direction which is the same as said first direction so that the sheet-like article is not inverted when laid out on said support surface.

20 Preferably said first speed is one of a range of first speeds, all of which are less than said second speed.

Preferably said second speed is one of a range of second speeds all of which are greater than said first speed.

25 Preferably said support surface is a table and said means comprises a mobile frame which supports said conveyor belt.

30 Preferably said table is extendable in a direction transverse said first direction so that when said sheet-like article is laid out on said table, the table can be extended in said transverse direction to transversely spread said sheet-like article.

Preferably said apparatus further comprises a pair of rotating spreader disposed and arranged so as to act on said sheet-like article as it passes from said conveyor belt to said support surface to spread said sheet-like article in a direction transverse to said first direction.

In an alternate embodiment, said support surface comprises an upper run of a second conveyor belt and said means comprises a drive system for effecting movement of said second conveyor belt.

10 An embodiment of the present invention will now be described by way of example only with reference to the accompanying drawings in which:

Figure 1 is a side view of a first embodiment of the apparatus according to the present invention;

15 Figure 2 is a top view of the apparatus shown in Figure 1;

Figure 3 is a schematic representation of a second embodiment of the present invention;

Figure 4 is a schematic representation of a third embodiment of the apparatus;

20 Figure 5 is a schematic representation of a fourth embodiment of the apparatus;

Figure 6 is a schematic representation of a fifth embodiment of the apparatus;

25 Figure 7 is a schematic representation of a sixth embodiment of the present invention; and

Figure 8 is a schematic representation of a seventh embodiment of the present invention.

As shown in the accompanying drawings with particular reference to Figures 1 and 2, an apparatus 10 for spreading a sheet-like article such as a fleece of wool 12 comprises a conveyor belt 14 which is arranged to travel in a closed vertical loop for transporting the fleece 12 in a first direction T1 at a first speed. A support surface in the form of a wool table 16 is disposed at a level below the conveyor belt 14 so that the fleece 12 can pass from the conveyor belt 14 to the table 16. Means in the form of a mobile frame 18 is provided for effecting relative movement of the conveyor belt 14 and table 16 at a second speed which is greater than the first speed. The frame 18 supports the conveyor belt 14 and is provided with one or more uprights 20 each having at their respective lower ends a trolley block 22. Each trolley block is arranged to travel along a floor mounted rail 24. A drive system 26 is also provided for driving the frame 18 toward and away from the table 16 at a second speed which is higher than the speed of travel of the conveyor belt 14. On the right hand side of the conveyor 14 is a further conveyor 28 which forms part of a wool harvesting system with which the present apparatus 10 may be used.

In an initial position, the conveyor belt 14 is to the right of the table 16 with one end 30 near the end of conveyor 28 and an opposite end 32 near but spaced from the table 16. The harvested fleece 12 is moved by conveyor 28 so as to fall onto conveyor 14 at end 30. The conveyor 14 then operates to transport the fleece to the end 32. Just prior to the fleece 12 reaching end 32, an electronic eye 34 detects the fleece 12. Upon detecting of the fleece, the conveyor belt 14 is stopped. When it is desired to spread the fleece 12, the drive means 26 operates so as to cause the mobile frame 18 to move in direction T1 over the table 16, which in terms of relative movement is equivalent to table 16 moving in an opposite direction T2 under the belt 14. Simultaneously, the conveyor belt 14 is also

operated to transport the fleece 14 in a direction so that it commences to fall off end 32 and passes onto the underlying table 16. As the frame 18 is moving toward the table 16 at a higher speed than the conveyor belt 14 is travelling, the fleece is laid out on the table 16 at a faster rate than it is paid out from the conveyor belt 14. This difference in speed has the effect of stretching or spreading the fleece lengthways. Also, it will be seen that in relative terms, the table 16 and conveyor belt 14 are moving in opposite directions. Because of this, as the fleece passes from the conveyor belt 14 to the table 16, it will be inverted.

The degree of spreading or stretching of the fleece in a lengthwise direction can be varied by changing the difference in speed between the speed of travel of the conveyor belt 14 and the speed of movement of the frame 18.

In a variation of the apparatus 10 shown in Figure 3, the frame supporting conveyor belt 14 is stationary and the table 16 is arranged to move in a direction T2 to pass under the conveyor belt 14. Again, the speed of travel of the table 16 in a direction T2 is higher than the speed of travel of conveyor belt 14 so as to provide the spreading effect.

In a further variation of the embodiment shown in Figure 3, the starting position of the table 16 may be beneath the conveyor belt 14 so that when it is time to spread the fleece, table 16 is moved in direction T1 at the second speed. In this variation, it will be appreciated that the fleece will be laid out on table 16 in the same way up as it is disposed on the conveyor belt 14.

In the embodiment shown in Figure 4, the table 16 is itself replaced with a conveyor belt 36. Upper run 38 of the conveyor belt 36 in effect provides a support surface for

the fleece 12. The upper run 38 of the conveyor belt 36 moves in the same direction as the upper run of conveyor belt 14 (i.e. direction of travel T1 of fleece 12 when on belt 14) but the speed of travel of conveyor belt 36 is higher than that of conveyor belt 14. Due to the difference in relative speeds, the fleece 12 will be spread or stretched when passed from conveyor 14 to conveyor 36. Further, as the direction of movement of the upper runs of the conveyor belts 14 and 36, T1 and T2, are the same, the fleece will not be inverted when passing onto conveyor belt 36.

In a further variation of the embodiment shown in Figure 4, which is depicted in Figure 5, the conveyor belts 14 and 36 may be disposed at the same level.

In yet a further embodiment as shown in Figure 6, the conveyor belt 36 is disposed beneath the conveyor belt 14 and is arranged so that its upper run 38 travels in a direction T2 opposite the direction of travel T1 of the upper run of conveyor belt 14.

In yet a further embodiment, which is applicable where the support surface 16 is in the form of a table as depicted in Figures 1-3, the table 16 can be formed with a plurality of telescopically extendable transversely laid slats 40 so that when fleece 12 has been laid on the table 16, the table can be effectively widened so as to spread the fleece in the transverse direction. This may be achieved by hydraulic or electrical means for moving opposite sides of the table 16 apart so as to telescopically extend the slats 40. To assist in the transverse spreading of the fleece 12, the slats 40 can be provided with means for gripping, catching or otherwise engaging the fleece.

In a further embodiment of the apparatus 10 shown in Figure 8, transverse spreading of the fleece 12 can be achieved by

5 providing a pair of rotating spreaders 42 near end 32 of
conveyor 14. The spreaders 42 are in the form of rotating
wheels 44 provided with radially extending fingers 46. The
axes of rotation of wheels 44 are disposed so as to
10 converge in a direction away from conveyor 14 and the
wheels 44 rotated in a direction so that when they engage
the fleece 14 they tend to spread the fleece outwardly away
from the centre. The spreaders 42 may be in the form of
rotating mops or buffers provided with fingers 46 made from
15 textile or plastics materials. Of course, the spreaders 42
may be supported on or with support surface 16 rather than
on the conveyor 14.

15 Now that embodiments of the present invention have been
described in detail, it will be apparent to those skilled
in the relevant arts that numerous modifications and
variations may be made without departing from the basic
inventive concepts. For example, in Figure 1, the conveyor
14 is shown as having a horizontal portion and a contiguous
inclined portion. However, conveyor belt 14 may be of any
20 suitable configuration including wholly horizontal, or
wholly inclined upwardly or downwardly. Further, the
conveyor 14 may form part of a larger wool harvesting
system of the type described in the above-referenced patent
applications in the name of the applicant. That is, with
25 reference to Figure 1, the conveyor 14 and conveyor 28 may
be one and the same.

30 All such modifications and variations are deemed to be
within the scope of the present invention, the nature of
which is to be determined from the foregoing description
and the appended claims.

THE CLAIMS DEFINING THE INVENTION ARE AS FOLLOWS:-

1. An apparatus for spreading a sheet-like article comprising:
 - 5 a conveyor belt arranged for transporting said sheet-like article in a first direction at a first speed;
 - a support surface disposed at or below the level of said conveyor belt to which said sheet-like article can pass; and,
 - 10 means for effecting relative movement between said support surface and said conveyor belt at a second speed which is greater than said first speed;
 - whereby, in use, when said sheet-like article is disposed on said conveyor belt and said conveyor belt operated to transport said sheet-like article in a first direction so as to commence to pass onto said support surface, said means can be simultaneously operated to cause said relative movement between said conveyor belt and said support surface so that said sheet-like article is laid out on said support surface at a greater speed than it is paid out from said conveyor belt thereby spreading said sheet-like article.
2. An apparatus according to claim 1, wherein said means effects movement of said support surface relative to said conveyor belt in a second direction opposite to said first direction so that said sheet-like article is inverted when laid out on said support surface.
3. An apparatus according to claim 1, wherein said second direction which is the same as said first direction so that the sheet-like article is not inverted when laid out on said support surface.
4. An apparatus according to any one of claims 1 to 3, wherein said first speed is one of a range of first speeds, all of which are less than said second speed.

5. An apparatus according to any one of claims 1 to 4, wherein said support surface is a table and said means comprises a mobile frame which supports said conveyor belt.

6. An apparatus according to any one of claims 1 to 4, wherein said support surface comprises an upper run of a second conveyor belt and said means comprises a drive system for effecting movement of said second conveyor belt.

7. An apparatus according to claim 5, said table is extendable in a direction transverse said first direction so that when said sheet-like article is laid out on said table, the table can be extended in said transverse direction to transversely spread said sheet-like article.

8. An apparatus according to any one of claims 1 to 6, further comprising a pair of rotating spreader disposed and arranged so as to act on said sheet-like article as it passes from said conveyor belt to said support surface to spread said sheet-like article in a direction transverse to said first direction.

9. An apparatus substantially as herein described with reference to and as illustrated by the accompanying drawings.

Dated this 8th day of May 1997.

CHAIN SHEARING LTD
By its Patent Attorneys:

25 GRIFFITH HACK
Fellows Institute of Patent
Attorneys of Australia.

ABSTRACT

An apparatus 10 for spreading a sheet-like article, such as a fleece of wool 12 comprises a conveyor belt 14 which is arranged to travel in a closed vertical loop for transporting the fleece 12 in a first direction T1 at a first speed. A support surface in the form of a table 16 is disposed at a level below that of the conveyor belt 14 so that the fleece 12 can pass from the conveyor belt 14 to the table 16. A mobile frame 18 is provided for effecting relative movement of the conveyor belt 14 and table 16 at a second speed which is greater than the first speed. The frame 18 which supports the conveyor belt 14 is provided with a trolley block 22 which travels along floor rails 24. A drive 26 is provided for driving the frame 18 toward and away from table 16 at the second speed. As the frame 18 is moving toward table 16 at a higher speed than the conveyor belt 14 is travelling, the fleece is laid out on the table 16 at a faster rate than it is payed out and thus is stretched or spread in a lengthways direction.

1/3 20141/97

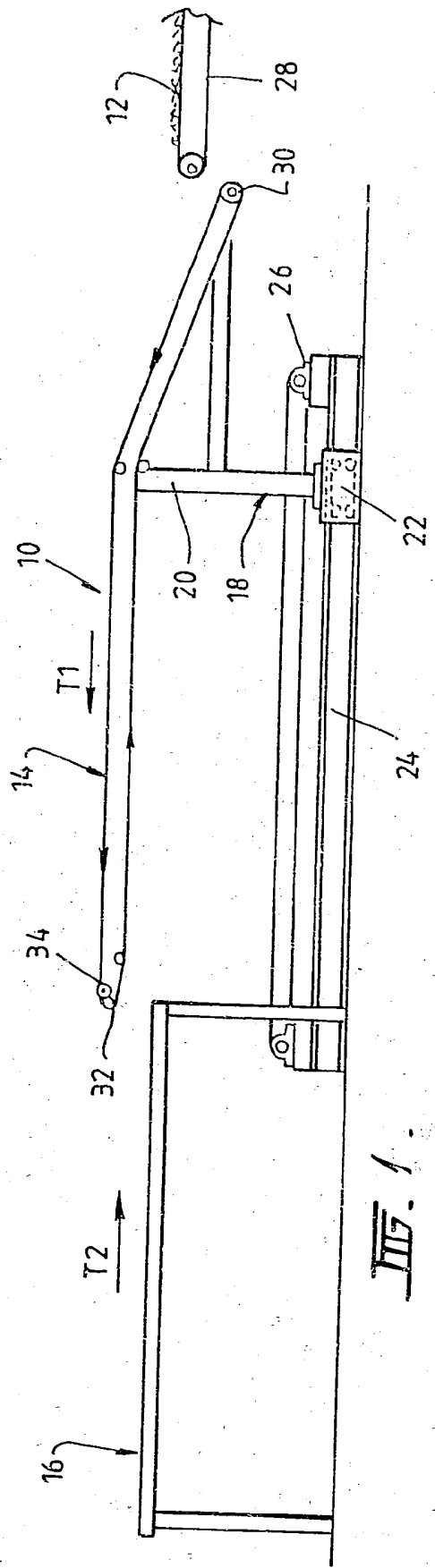

FIG. 1.

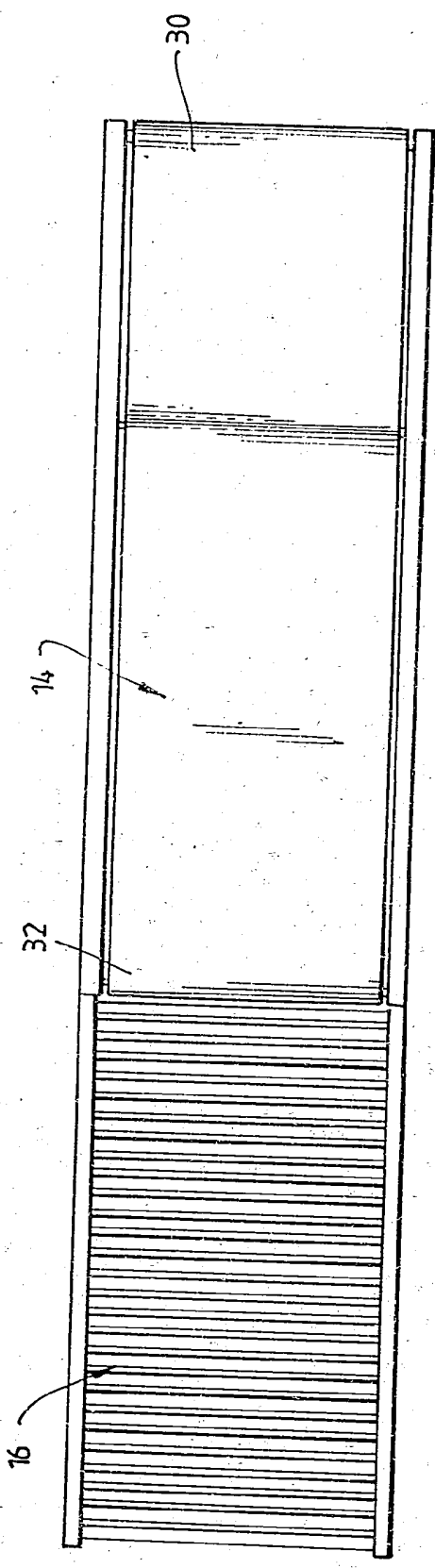

FIG. 2.

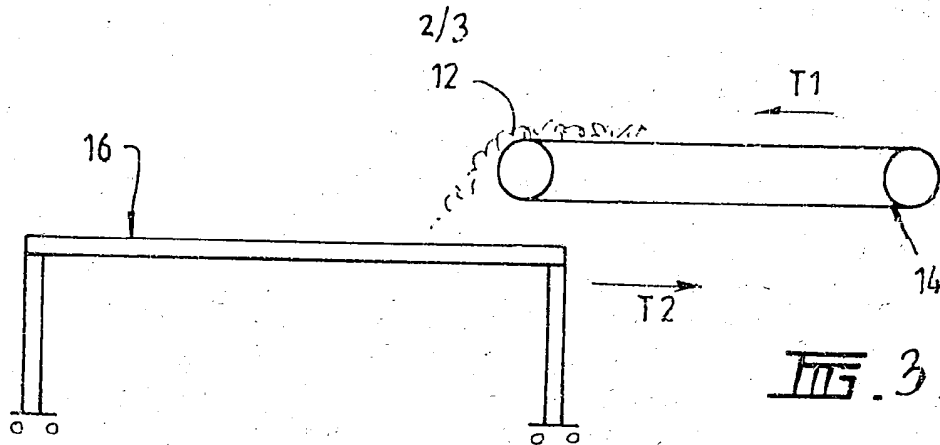

FIG. 3.

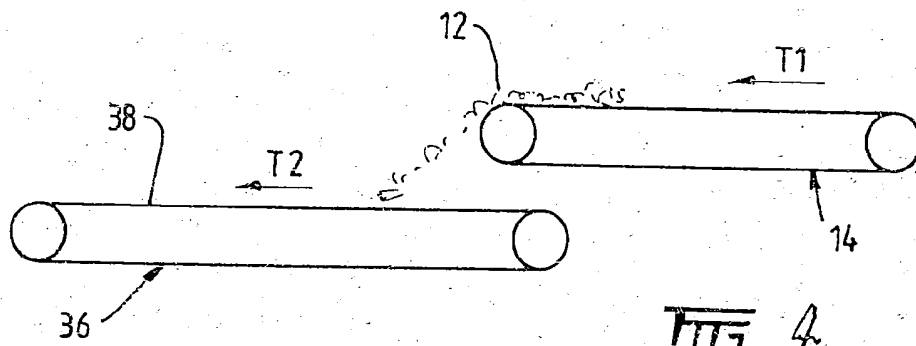

FIG. 4.

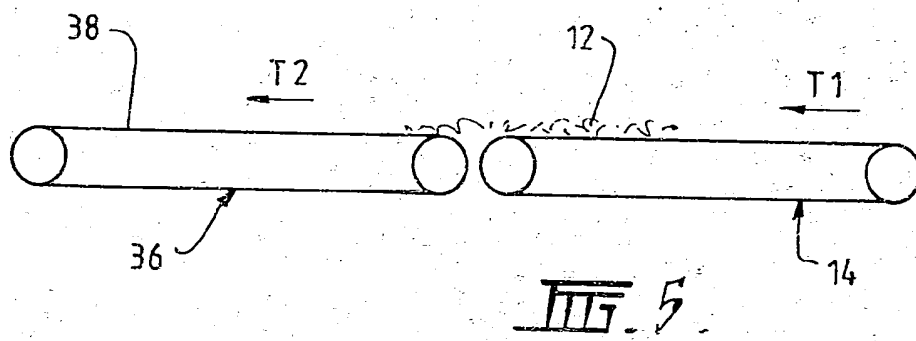

FIG. 5.

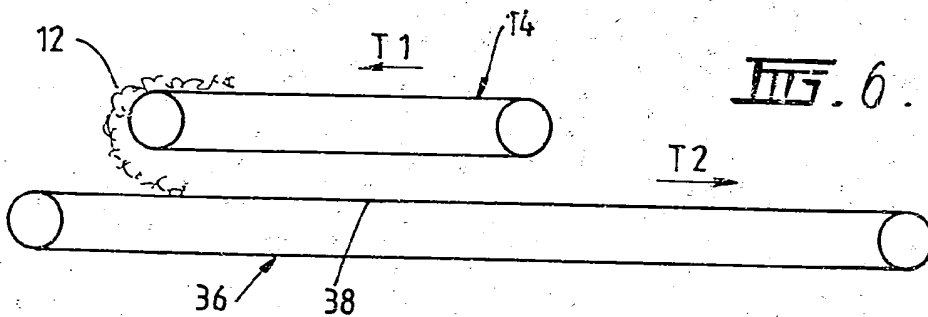

FIG. 6.

3/3

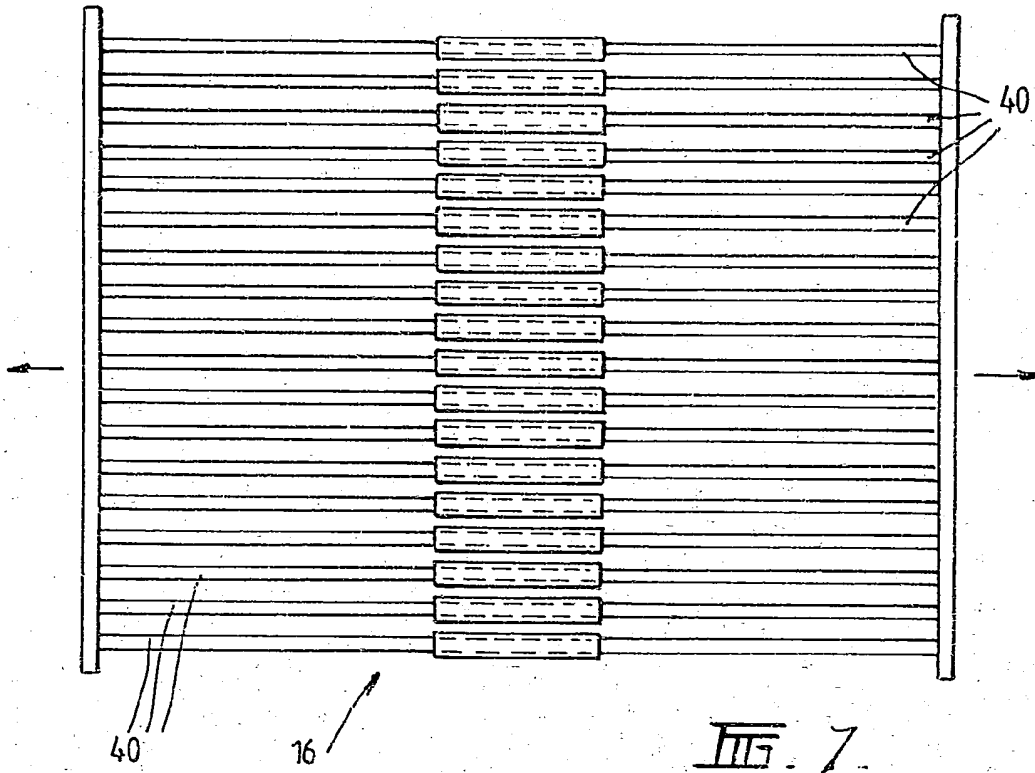

FIG. 7.

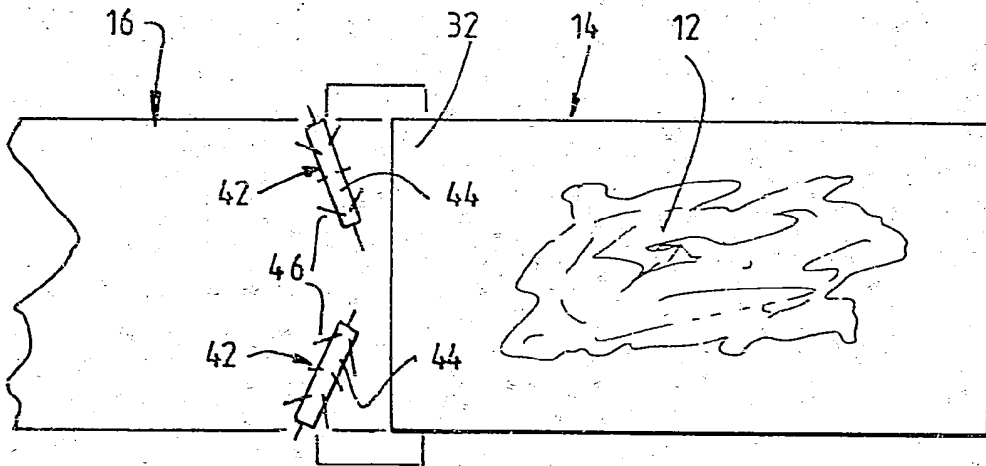

FIG. 8.