

(12) PATENT
(19) AUSTRALIAN PATENT OFFICE

(11) Application No. AU 200157792 B2
(10) Patent No. 755887

(54) Title
Mobile collapsible shelter

(51)⁶ International Patent Classification(s)
E04H 015/02 E04H 015/06
B60P 003/355

(21) Application No: 200157792 (22) Application Date: 2001 . 08 . 03

(30) Priority Data

(31) Number	(32) Date	(33) Country
PQ9243	2000 . 08 . 07	AU

(43) Publication Date : 2002 . 02 . 14
(43) Publication Journal Date : 2002 . 02 . 14
(44) Accepted Journal Date : 2003 . 01 . 02

(71) Applicant(s)
Chain Shearing Limited

(72) Inventor(s)
Fred Wybrow

(74) Agent/Attorney
GRIFFITH HACK, 256 Adelaide Terrace, PERTH WA 6000

(56) Related Art
US 3415260
JP 09-060349
US 2817344

ABSTRACT

Mobile shelter 10 includes a trailer 12, a collapsible and extendable shelter frame 14, and a cover 16 that can be extended over the shelter frame 14. Frame 14 is composed of a plurality of support elements 18 that are coupled by cables 20. When the shelter frame 14 is in a collapsed state the support elements are mutually adjacent each other and carried on the trailer 12, while in the expanded state, the support elements 18 are deployed from the trailer 12 and spaced by a distance governed by spreader cables 22 that are attached to the support elements 18. One end of each cable 20 is attached to respective winches 66 on the trailer 12. Cables 20 pass through pulley wheels 48 attached to the support elements 18, and have their opposite end attached to anchor posts 78. To deploy the shelter from the trailer 12, once the anchor posts 78 have been driven into the ground, a front support element 18 is pulled or dragged along the cables 20, dragging in with it the following support elements 18 thereby deploying the frame 14. The cover 16 is then extended over the frame 14.



AUSTRALIA
Patents Act 1990

COMPLETE SPECIFICATION
STANDARD PATENT

Applicant(s) :

CHAIN SHEARING LIMITED
A.C.N. 070 843 373

Invention Title:

MOBILE COLLAPSIBLE SHELTER

•••
•••
•••
•••
•••

•••
•••
•••

•••
•••
•••

•••
•••
•••

The following statement is a full description of this invention, including the best method of performing it known to me/us:

MOBILE COLLAPSIBLE SHELTER

The present invention relates to a mobile collapsible shelter and in particular, but not exclusively, to a mobile shearing shed.

5

Conventionally, a wool farm will have a fixed shearing shed which will contain all the equipment required to shear sheep. Often the shearing shed also includes amenities for the shearers. The typical practice is to herd the sheep from wherever they may be on the farm to the shearing shed, pen the sheep and then sequentially pass the sheep through the shearing shed.

10

The present invention was developed to allow for at least a partial reversal in the above procedure in which the shearing shed is brought to the sheep rather than the sheep brought to the shearing shed. In this regard the Applicant has been particularly innovative in the development of various devices, methods and systems for harvesting wool. One such innovation relates to a mobile wool harvesting system which allows for the sequential harvesting of wool from a sheep by a plurality of wool harvesters.

15



An embodiment of the present invention can provide a shed for accommodating the mobile harvesting system. However, as will be apparent from the following description, embodiments of the mobile collapsible shelter are not restricted for use in conjunction with the mobile harvesting system or wool harvesting in general. Embodiments of the present invention can be used for any desired purpose.

20



25

According to the present invention there is provided a mobile collapsible shelter including at least:

a vehicle;

a shelter frame comprising a plurality of support elements, said shelter frame having a collapsed state in which said support elements are spaced a minimum distance from each other and carried on the vehicle and an expanded state in which said support elements are deployed from the vehicle and separated by a second distance being

30



greater than said minimum distance;

one or more cables extendible in respective straight lines, said cables attached at one end to the vehicle and coupled to each of said support elements; and

roofing means transportable on said vehicle and extendible over said shelter
5 frame;

whereby in use, to place said shelter in said expanded state, said one or more cables are extended in straight lines and anchored at an end distant said vehicle and said support elements are pulled or dragged along said one more cables.

10 Preferably said mobile collapsible shelter further includes anchor means to which an opposite end of said one or more cables is attached, the anchor means adapted for providing an anchor point for said one or more cables at a location distant said vehicle, whereby in use said support elements can be supported by said cables when being deployed and returned to
15 said vehicle and when the shelter frame is in the expanded state.

Preferably each support element includes a roof truss and pair of legs, one at each end of said roof truss, to support said roof truss above the ground when said shelter frame is in the expanded state.

20 Preferably each leg is coupled to its corresponding roof truss by a mounting bracket configured to enable the legs to be disposed in an upright condition when the shelter frame is in the expanded state and to be disposed in a stored condition in or over respective end lengths of said roof truss when said shelter frame is in the collapsed state.

25 Preferably said mounting bracket is further configured to enable the legs to pivot from the upright condition and telescope into or over said respective end lengths of said roof truss.

30 Preferably each leg is provided with engaging means adapted to be engaged by said mounting bracket when the leg is in a stored condition to thereby hold the leg in the stored condition.

Preferably each roof truss includes a centrally disposed arcuate portion which is configured so that when said roofing means is extended over said support elements the roofing means, when viewed from outside the shelter frame, forms a convexly curved



roof.

Preferably each of said support elements is provided with guide means through which said one or more cables can pass.

5

Preferably said guide means is in the form of a pair of spaced apart pulleys attached to each roof truss wherein said respective ones of said cables pass through different pulleys.

An embodiment of the present invention will now be described by way of example only with reference to the accompany drawings in which:

- 10
- Figure 1 is a schematic representation of the mobile shelter in an expanded state;
Figure 2 is a front view of a support element in a deployed condition incorporated in the mobile shelter when in a deployed condition;
15 Figure 3 is a rear end view of the mobile shelter in the expanded state;
Figure 4A is a side view of a vehicle end of the mobile shelter in the expanded state;
Figure 4B is a side view of an anchor end of the mobile shelter in the expanded state;
Figure 5 is an enlarged view of a portion of the support element incorporated into the mobile shelter;
20 Figure 6 is a side view of the support element shown in Figure 5;
Figure 7 is a side view of a cover storage frame incorporated in the mobile shelter;
Figure 8 is an elevated view of an end panel of a cover incorporated in the mobile shelter; and
Figure 9 is an elevation view of a door panel incorporated in the cover.

25

Referring to the accompanying drawings and in particular to Figures 1-4B, the mobile shelter 10 includes a vehicle in the form of a trailer 12, a selectively collapsible and expandable shelter frame 14, and a roofing means in the form of a cover 16 that can extend over the shelter frame. The shelter frame 14 is composed of a plurality of support
30 elements 18 which are coupled by cables 20. The shelter frame 14 has a collapsed state in which the support elements 18 are spaced a minimum distance apart, namely mutually

adjacent and carried on the trailer 12, and an expanded state in which the support elements 18 are deployed from the trailer 12 and spaced by a second distance, greater than the minimum distance. The distance between adjacent support elements 18 in the expanded state is governed by attaching one or more spreader cables 22 to each of the support elements 18. In this way, the second or maximum distance between adjacent support elements 18 is determined by the length of spreader cable 22 between adjacent support elements 18.

With reference to Figures 2, 5 and 6 each support element 18 is formed of a roof truss 24 and a pair of legs 26, one at each end of the truss 24 for supporting to roof truss 24 above the ground 28 when the shelter frame 14 is in the expanded state. The roof truss 24 is composed of a central arch 30 with contiguous straight end lengths 32 at its opposite end. The end lengths 32 are attached to the arch 30 by way of two bolts 34 which pass through opposing plates 36 that span adjacent ends of the lengths 32 and arch 30.

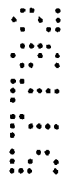

An anchor point or bracket 35 is also provided at the centre of each arch 30 to which is attached an additional spreader cable (not shown). The spreader cable further assists in setting the distance between adjacent trusses 24 and also serves to support the cover 16 from the inside.



A bracket 38 is attached to the free or distant end 40 of the roof truss 24. The bracket 38 is in the form of a pair of parallel spaced apart plates 42 which are attached, for example by welding, to the ends 40 of the truss 24. The plates 42 are each provided with a pair of holes which are in mutual alignment to receive respective pins 44. Each leg 26 is also provided with a pair of holes which can register with the holes in the plates 42. When the shelter frame is in the expanded condition as depicted in, for example Figures 2 and 5, the legs 26 are upright, depending downwardly from the ends 40 of the roof truss 24 and are locked in place by the pins 44 passing through the holes in the plates 42 and in the legs 26.



When it is desired to collapse the shelter frame 14 so that it is carried on the trailer 12, the pins 44 are pulled out of the bracket 38 and the legs 26 are telescoped into respective



adjacent end lengths 32. When in this configuration, the legs 26 are in a stored state. Each leg 26 is provided with a hole 46 at an end distant the truss. In order to hold the legs 26 in the stored state, the leg 26 is jugged to place the hole 46 in registration with an upper one of the holes of the bracket 38 and then one of the pins 34 is inserted through the bracket 38 and the hole 46. The other pin 44 is reinserted into the other hole of the bracket 38 for safekeeping.

A guide in the form of a pair of spaced apart pulley wheels 48 are symmetrically disposed on, and attached to, the arch 30 of the roof truss 34. Each pulley wheel 48 is of conventional construction having an outer pulley bracket 50 in which is rotatably mounted a sheave 52. A rubber pad 54 is placed between an end of each bracket 50 and an upper surface of the arch 30. A bolt 56 passes through the bracket 50, rubber pad 54, arch 30 and an underlying plate 58 to attach the pulley 48 to arch 30.

Referring to Figures 3, 4A and 7, the trailer 12 has a base frame 60 of generally conventional construction with a suspension system and wheels. However mounted on the trailer frame 60 is a shelter storage frame 62. The shelter storage frame includes a pair of spaced apart uprights 64 to each of which is attached a corresponding winch 66. One end of each cable 20 is attached to respective ones of the winches 66. Also attached to each upright 64 above each winch 66 is a corresponding pulley wheel 68 about which the cable 20 turns. Extending horizontally from each upright 64 at a location adjacent the pulley wheels 68 is a support beam 70. Releasably attached near an opposite end of each beam 70 is an arm 72. The arm 72 is releasably attached to the beam 70 by way of a pin 74. An opposite end of the arm 70 is pivotally coupled to another beam 76. The beam 76 runs parallel to the beam 70 and is coupled at its opposite end back to the upright 64.

When the shelter frame 14 is in the collapsed state, the support elements 18 are supported by the beams 70. The beams 70 support the elements 18 and in particular the arches 30 at locations in general alignment with the pulley wheels 48. When the shelter frame 14 is in the collapsed state, the legs 26 are in their stored position, being telescoped into the end lengths 32.

In order to erect the shelter frame 14, the opposite ends of the cables 20 are attached to anchor means in the form of posts 78 which are placed a distance away from the trailer 12 and driven into, or otherwise attached to, the ground 28. Next, the support elements 18 are wheeled along the cables 20 by their pulley wheels 48. Because such support elements 18 are coupled by spreader cables 22, pulling or dragging the first of the support elements 18 along the cables 20 to its desired location will also drag or pull the other support elements 18 from the trailer 12 along the cables 20. The legs 26 are now released from their stored position by removing one of the pins 44 from the holes 46 to allow the leg 26 to slide out of the corresponding length 32. The legs 26 are then locked into their upright condition as depicted in Figure 5 by appropriate manipulation of the bracket 38. When all the support elements 18 have been deployed from the trailer 12, they can be further anchored in position by use of stays 80 coupled to the top of legs 26 and extending laterally of the elements 18. The cover 16, typically in the form of a large tarpaulin of compliant material, such as canvas or plastics material is draped over the support elements 18 to form a roof and side walls. Opposite ends of the shelter frame can be covered by separate panels 82, 84 of a same or similar type of materials used for the roof to form end walls of the shelter. Figure 8 depicts a sample of one form of end panel which completely closes a trailer end of the shelter. Figure 9 depicts a second end panel 84 which is provided with flaps or door panels to allow entry into the shelter. The end panels 82 and 84 can be attached by any conventional means to either the cover or the adjacent support elements 18, for example by hook and loop fastener or rope.

When it is desired to collapse the shelter frame 14 so that it can again be transported by the trailer 12, the end panels 82 and 84 are detached, the guide wires 80 released from engagement with the ground, the legs moved to their stored condition and the frame elements 18 wheeled along the cables 20 back onto the trailer 12 and in particular onto the shelter storage frame 62. The anchor posts 78 are then removed from the ground and also loaded onto the trailer 12.

Now that an embodiment of the present invention has been described in detail it will be

- apparent to those skilled in the relevant art that numerous modifications and variations may be made without departing from the basic inventive concepts. For example, the legs 26 could be fixed to the arch 30 rather than having the demountable mounting described above. Also, any number of spreader cables 22 can be provided between the adjacent
- 5 support elements 18. More particularly, spreader cables can be attached to and between brackets 38 at the opposite ends of trusses 24. The shelter can be made with any number of arches 18 and in any particular application is not necessary for all the arches 18 to be deployed.
- 10 All such modifications and variations together with others that would be obvious to a person of ordinary skill in the art are deemed to be within the present scope of the invention the nature of which is to be determined from the above description and the appended claims.

5
10
15
20
25
30

The Claims Defining the Invention are as Follows:

1. A mobile collapsible shelter including at least:
a vehicle;

a shelter frame comprising a plurality of support elements, said shelter frame
5 having a collapsed state in which said support elements are spaced a minimum distance
from each other and carried on the vehicle and an expanded state in which said support
elements are deployed from the vehicle and separated by a second distance being greater
than said minimum distance;

one or more cables extendible in respective straight lines, said cables
10 attached at one end to the vehicle and coupled to each of said support elements; and

roofing means transportable on said vehicle and extendible over said shelter
frame;

whereby in use, to place said shelter in said expanded state, said one or more cables are
15 extended in straight lines and anchored at an end distant said vehicle and said support
elements are pulled or dragged along said one or more cables.

2. A shelter according to claim 1 further including anchor means to which an
opposite end of said one or more cables is attached, the anchor means adapted for providing
20 an anchor point for said one or more cables at a location distant said vehicle, whereby in use
said support elements can be supported by said cables when being deployed and returned to
said vehicle and when the shelter frame is in the expanded state.

3. A shelter according to claim 1 or 2 wherein each support element includes a
25 roof truss and pair of legs, one at each end of said roof truss, to support said roof truss above
the ground when said shelter frame is in the expanded state.

4. A shelter according to claim 3 wherein each leg is coupled to its
corresponding roof truss by a mounting bracket configured to enable the legs to be disposed
30 in an upright condition when the shelter frame is in the expanded state and to be disposed in
a stored condition in or over respective end lengths of said roof truss when said shelter
frame is in the collapsed state.



5. A shelter according to claim 4 wherein said mounting bracket is further configured to enable the legs to pivot from the upright condition and telescope into or over said respective end lengths of said roof truss.

5 6. A shelter according to claim 4 or 5 wherein each leg is provided with engaging means adapted to be engaged by said mounting bracket when the leg is in a stored condition to thereby hold the leg in the stored condition.

7. A shelter according to any one of claims 3 to 6 wherein each roof truss
10 includes a centrally disposed arcuate portion which is configured so that when said roofing means is extended over said support elements the roofing means, when viewed from outside the shelter frame, forms a convexly curved roof.

8. A shelter according to any one of claims 1 to 7 wherein each of said
15 support elements is provided with guide means through which said one or more cables can pass.

9. A shelter according to claim 8 wherein said guide means is in the form of a
20 pair of spaced apart pulleys attached to each roof truss wherein said respective ones of said cables pass through different pulleys.

10. A mobile collapsible shelter substantially as herein described with reference to and as illustrated by the accompanying drawings.

25 Dated this 2nd day of August 2001.

CHAIN SHEARING LTD

30 By Its Patent Attorneys
GRIFFITH HACK

Fellows Institute of Patent and Trade Mark
Attorneys of Australia

OPTICAL SYSTEM

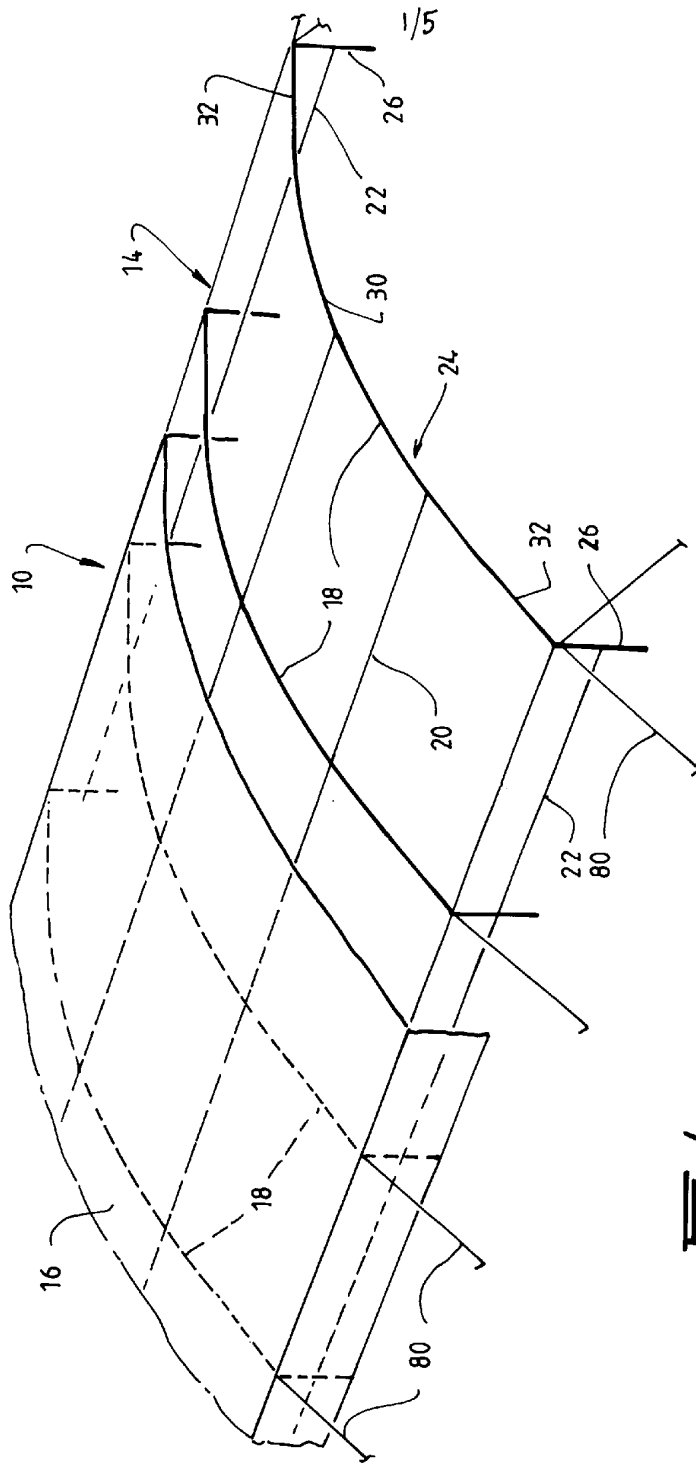

Fig. 1.

OPTICAL SYSTEM

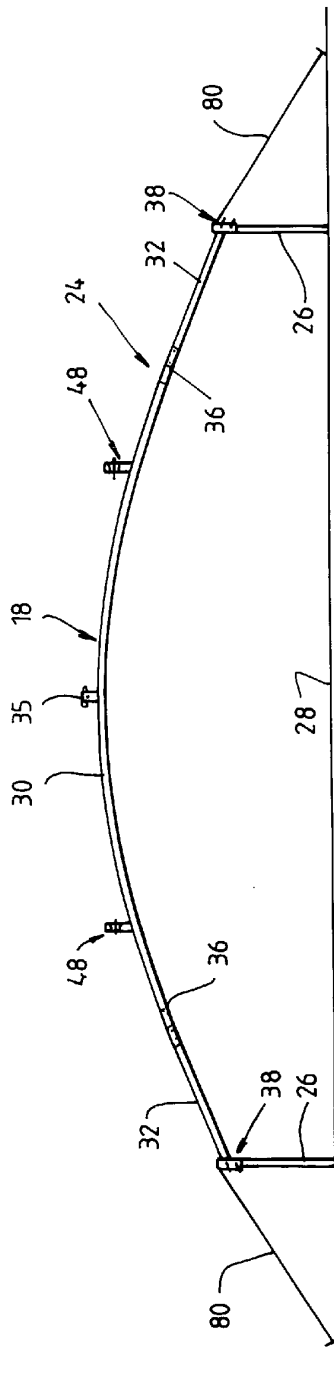

FIG. 2.

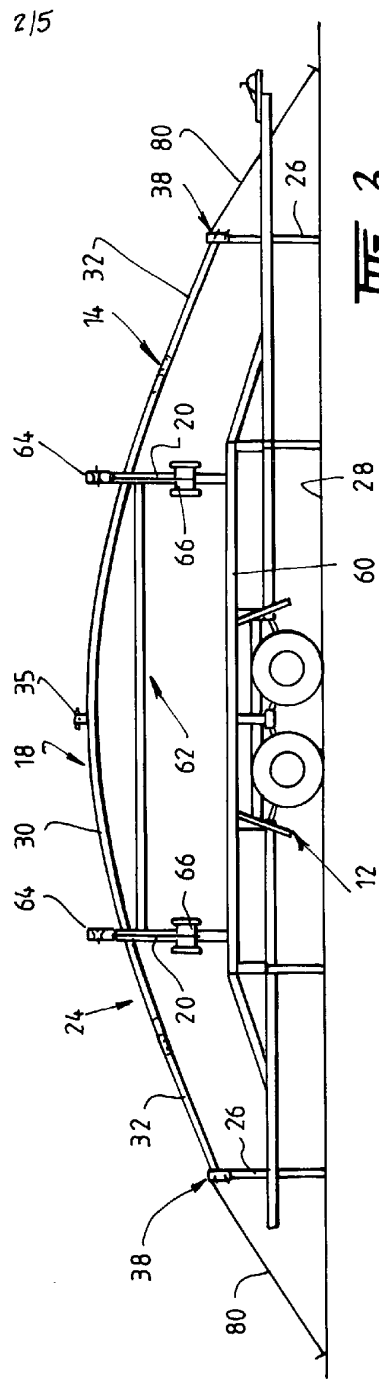

FIG. 3.

FIELD STUDY

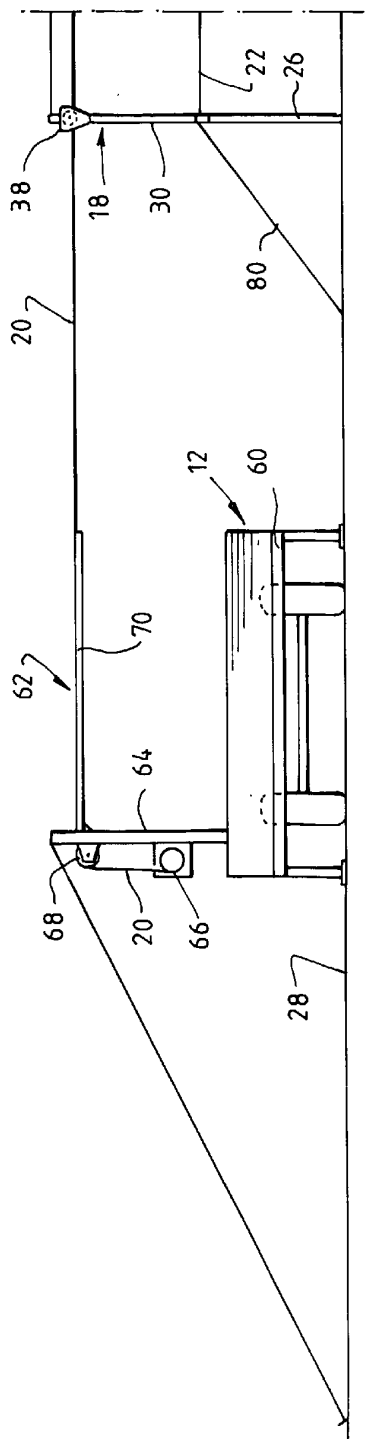

FIG. 4A.

315

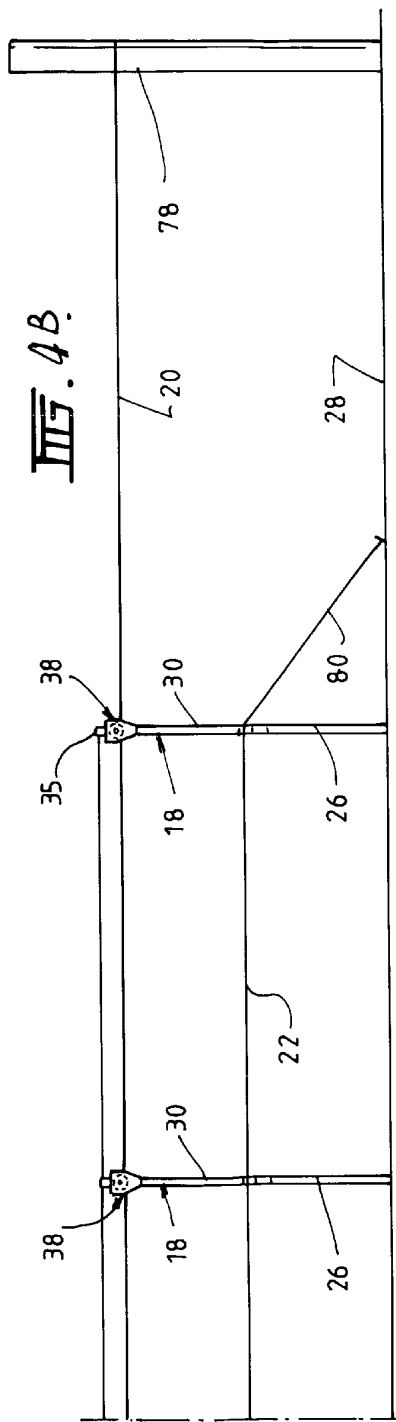
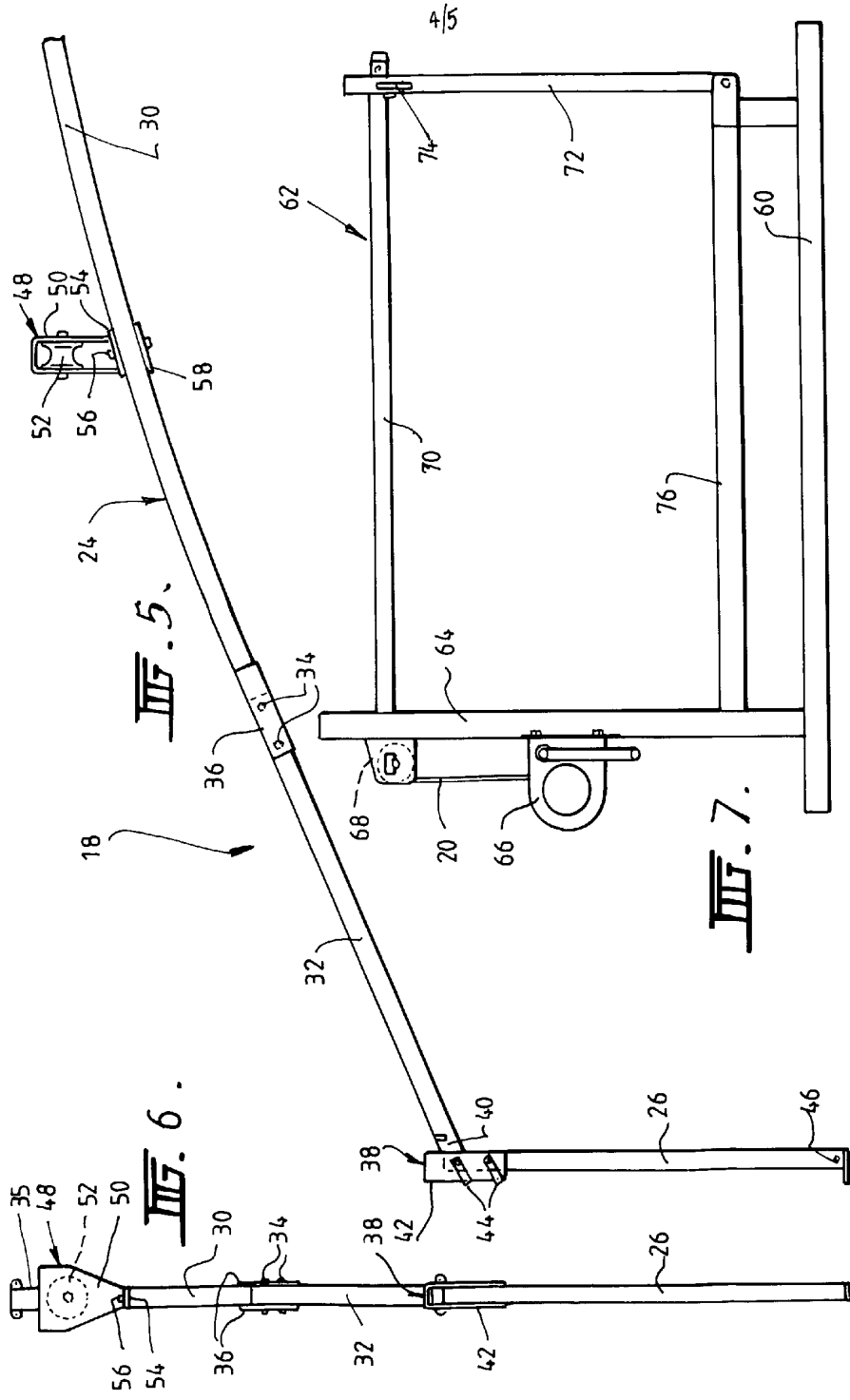
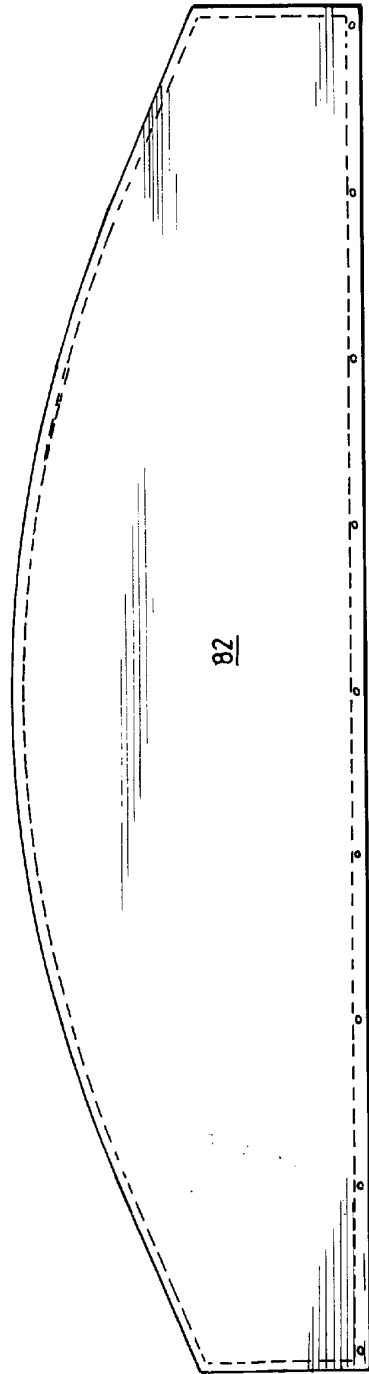

FIG. 4B.

ORIGINAL SPECIFICATION



071001 02700



III. 8.

5/5

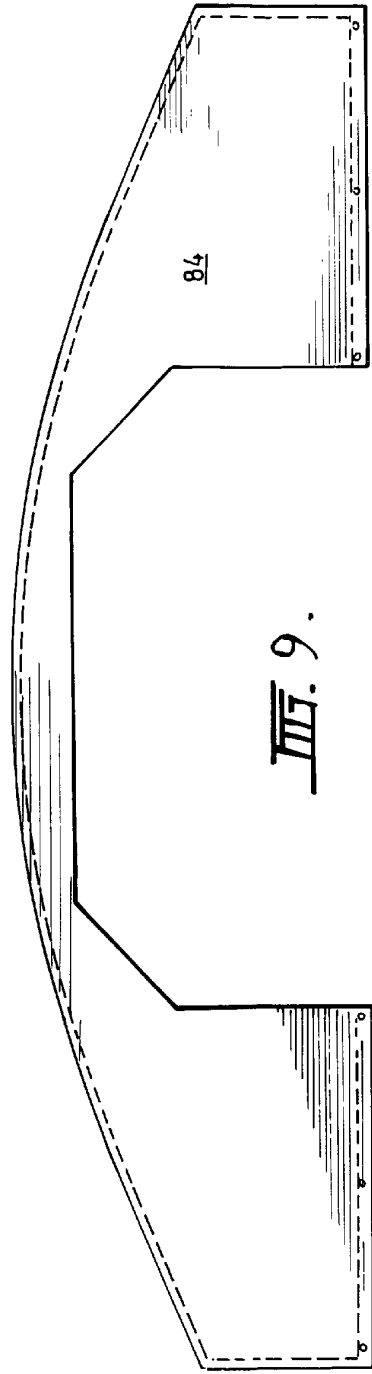

III. 9.